

Asada

REFRIGERANT RECOVERY MACHINE

ECOsaver Tetra

INSTRUCTION MANUAL

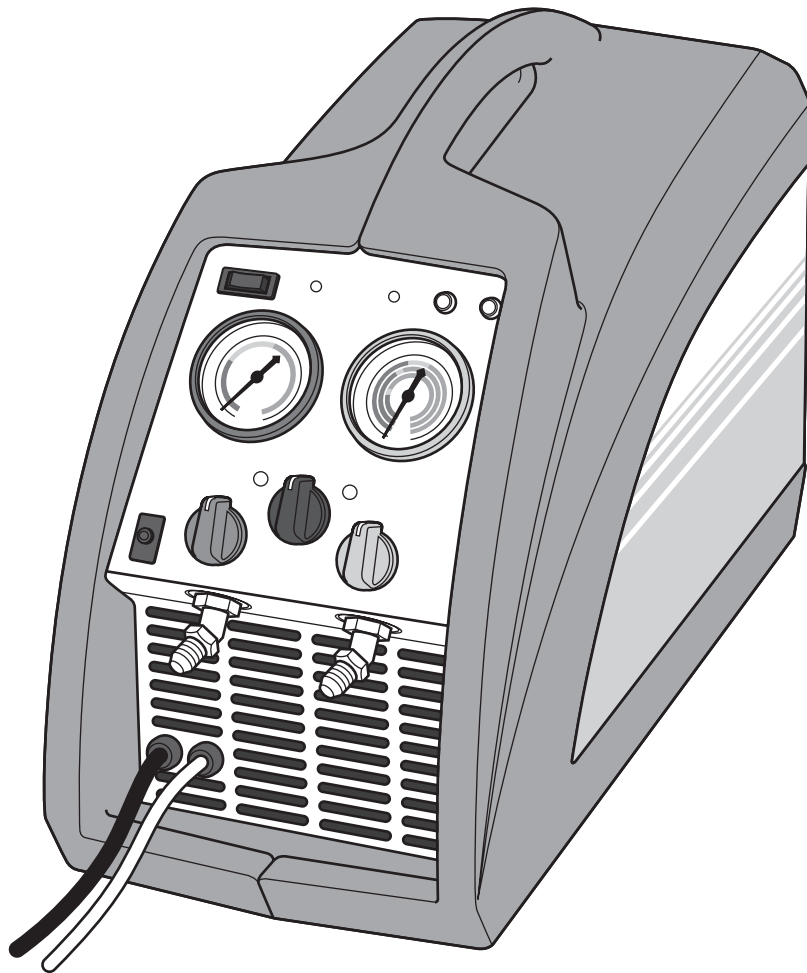

[Please read this manual before operating.]

ECO saver Tetra

FOR SAFE OPERATION

Thank you for selecting ECOsaver Tetra.

- Please give this Operation Manual to the persons who operate this machine.
- The contents of this manual must be thoroughly read by the operating persons.
- Obtain the highest performance efficiency of this machine by an appropriate safe operation.
- Keep this manual at a safe place easily accessible by operating person.
- Do not use this machine for purposes other than originally intended.
- Check the following as soon the unit is delivered:
 - Is the specification same as the ordered product?
 - Is there damage or deformation caused during delivery transit?
 - Is there shortage of accessories?

If any dissatisfaction is found, please contact the store you have purchased or our sales department.
(The contents of this manual may be changed without prior notice for changes made for improvement.)

CATEGORIES OF WARNING SIGNS

The warning signs used in this manual or on the product are divided in the following two categories

 **WARNING** Situation that may cause death or serious injury if the operating Personnel contact or stand near the machine or the third party person Erroneously operates the machine.

 **CAUTION** Situation that may cause minor to medium injury or may cause damage to the machine, if the operating personnel contact or stand near the machine or The third party person erroneously operates the machine.



INDEX

WARNING FOR SAFETY	2	Push/Pull Recovery Procedure	17
COMPONENTS OF THE MACHINE	6	Pressure Balancing between the Recovery Machine and the Cylinder	20
Name of Each Part	6	How to Purge Noncondensable Gases	20
Specification	7	How to Recover Different Type of Refrigerant	21
Standard Accessories	7	In Case the Machine Stops During Operation	21
Optional Accessories (Recovery Cylinder)	8	RECOVERY CYLINDER	22
Optional Accessories (Cooling Unit)	8	MAINTENANCE & INSPECTION	23
Optional Accessories (Other Air-Conditioning Equipment)	8	BEFORE REQUESTING REPAIR OR SERVICES	25
HOW TO USE	9	ELECTRIC WIRING DIAGRAM	26
Preparation before Operation	9	FLOW DIAGRAM	27
Standard Recovery Procedure	11		

ECOsaver Tetra

WARNING FOR SAFETY

- General warnings in operating this machine are mentioned in this section.
- While specific details are mentioned in each particular clause.

⚠ WARNING



- ◆ **When performing recovery, choose location that has good ventilation.**
Leakage of gas without sufficient ventilation may cause lack of oxygen cause suffocation.



- ◆ **Can not recover flammable gas (Hydrocarbon or this kind of hydrocarbon material) When mix except refrigerants [Ammonia, hydrocarbon(propane, isobutene,) etc] to the machine, it may cause explosion.**



- ◆ **Burning Freon creates a deadly poisonous Carbon Oxy-Chloride and inhaling of this gas is very dangerous.**
There should be absolutely no flammable material near the working area and must operate under good ventilation.



- ◆ **Absolutely no fire material and smoking during the work in process.**
Cigarette light may creates Carbon Oxy-Chloride and ignite fire.



- ◆ **Use protective eye glass and hand glove when disconnecting hoses.**
If Freon gas was touch your skin or gets in your eyes, it may cause frostbite or damage your eye-sight.



- ◆ **Do not close the valves of the machine and the hoses when they are full of liquid refrigerant.**
- ◆ **Do not operate or storage the machine at the place where temperature gets above 40°C .**
It may cause explosion for expand liquid gas on the higher temperature site. When the recovery operation will finish, do operation purge certainly.
- ◆ **Use our original recovery cylinders.**



- ◆ **Do not operate the machine with wet hands or in the rain.**
If you handle electric plug and power switch with wet hands or in the rain you may have electric shock.



- ◆ **Make sure to have the machine earthed (grounded).**
If the machine is not properly grounded, it may cause electric shock when the machine has electric leak.

ECOsaver Tetra

WARNING



- ◆ **Check electric power plug regularly to make sure there is no problem. Always have the plug inserted firmly.**
When the plug has dirt or oil, and the connection is incomplete, it may cause electric shock or fire.



- ◆ **Do not have the electric cord connected with other electric devices or branched with other cords.**
It may cause fire.



- ◆ **Do not pull the electric power source cord and remove from the outlet.**
It may cause fire or injury.
- ◆ **The power source should be AC220-240V 10A or use a generator whose capacity is 3KVA or more.**
If the capacity of the generator is not large enough, it may lead to heating, smoking or fire.
See the machine plate or this manual for the detailed specifications.



- ◆ **Do not setup the machine at location where gasoline, thinner, or flammable Gas exists.**
The recovery machine sparks at the start-up time and may ignite gasoline and thinner.
If leaked gasoline or flammable gas accumulates at near the machine, it may cause explosion and fire.



- ◆ **Always turn off the switch and pull out the power source cord when performing inspection and maintenance.**
The machine may suddenly start and cause accident.



- ◆ **Do not disassemble by un-authorized repair person.**
- ◆ **Do not operate the machine with the cover removed.**
It may cause abnormal movement and may cause injury or damage.

ECOsaver Tetra

CAUTION



- ◆ **Install a filter drier at the suction port.**
Otherwise the compressor may be damaged.



- ◆ **An extension cord used should be a three-core cable with a length of 20m or less when its wire diameter is 2.0mm² or with a length of 30m or less when its wire diameter is 3.5mm².**



- An unsuitable extension cord (too thin or too long) may lead to starting failure or fire. Or electrical components such as capacitor, relay and so on may be damaged.
If the cord used is a two-core cord without a ground wire, you may get electric shock.



- ◆ **Do not recover refrigerant which contains sealant.**
Sealant may clog the valves or the check valves.

- ◆ **When you do not know the refrigerant to be recovered is in the form of liquid or in the form of vapor, try liquid recovery.**

If liquid refrigerant goes into the compressor under the vapor recovery procedure, the compressor may be damaged.

- ◆ **Do not let visitors touch the machine.**

- ◆ **Do not use the machine when the result is unpredictable.**

- ◆ **Do not use the machine for purposes other than the original intent.**
This machine is designed to recover the specified refrigerants.

- ◆ **Do not operate under an excessive heavy load to the machine.**
Operating under an excessive load can not only cause damage to the machine but also causes an accident.

- ◆ **Do not use the machine on a vibrating floor or on a sloping place.**
The machine or the cylinder may fall down and lead to accident.

- ◆ **The operating platform and the work area must be kept neat and clean. at all time and have enough lighting.**
Poor working environment causes accident.

- ◆ **Do not operate the machine if the operator is under fatigue condition or influenced by alcoholic drink or medicines.**

- ◆ **When the Recovery Machine is not in use, storage at dry space and out of reach by children.**

- ◆ **Do not use accessories other than referred in this manual or shown on our catalogue. Use of other accessories may cause problem.**

- ◆ **Use a cylinder whose port size is 3/8" or more.**

ECOsaver Tetra

CAUTION



- ◆ **When the Recovery Machine is dropped or hit, inspect immediately for damage, crack, dent, etc.**

Recovery under damaged, cracked and dented condition may cause injury

- ◆ **Check every day if there is deformed or corroded area.**



- ◆ **If abnormal condition (strange smell, vibration, strange noise) is noticed, stop the unit and refer to the Page24 “BEFORE REQUESTING REPAIR OR SERVICES” in the manual.**



- ◆ **Request for repair or service instead of disassembling for repair, contact the store where the machine was purchased.**



- ◆ **Use our cylinders that are expressly made for recovery and recycling.**

ECOsaver Tetra

COMPONENTS OF THE MACHINE

Name of Each Part

Labels are required by law for safety and the warnings are placed on the recovery machine. If the label comes off the machine or became dirty and unreadable, request us for new label. Replace the label at the same position on the machine.

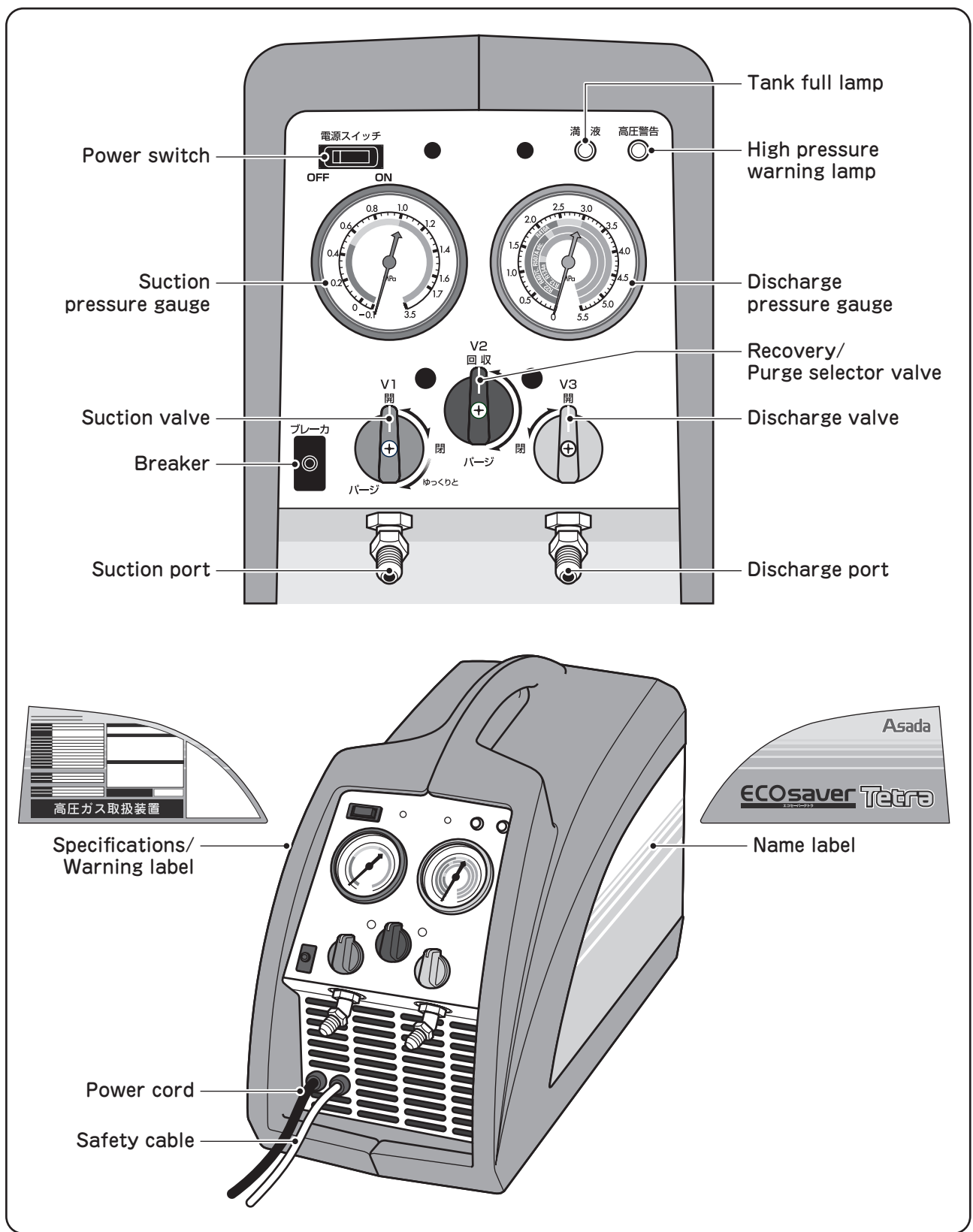

ECOsaver Tetra

Specifications

Item	ECOsaver Tetra
Code No.	ES802
Applicable refrigerant	R12, R22, R500, R502, R134a, R404A, R407C, R407D, R422A, R422D, R507A, R509A, R32, R1234yf, R1324ze, R115, R125, R218, R401A, R401B, R402A, R402B, R407A, R407B, R407E, R410A, R410B, R410JA, R900JA, R901JA, R448A, R449A, * R463A, R463A-J, R407H, R452A * The R463A requires a special cylinder.
Recovery method	Compressed vapor recovery method, Push/Pull method
Power source	Single phase 220-240V
Compressor	750W (1HP) Oil less 4 cylinders
Dimensions (LxWxH)	560 x 250 x 380mm
Weight	22kg
Power consumption	859/955W (50/60Hz)
Operating current · Starting current	4.5A / 4A (50/60Hz) · 44A
Operating temperature	0 ~ 40°C
Ultimate vacuum	- 0.09MPa
Applicable cylinder	Float sensor type : Recovery cylinder (with float sensor) 24L · 40L · 120L Weighing type : Recovery cylinder (without float sensor) with Digital scale with overfill prevention device 24L · 40L · 120L

Recovery rate	R22	R134a	R410A
Vapor (g/min)	400	315	325
Liquid (g/min)	6,910	4,670	7,190
Push/Pull (g/min)	20,140	19,200	19,270

* Specifications are subject to change without prior notice.

* Recovery rates vary under different conditions.

Standard Accessories

Item	Code No.
ECO SAVER Tetra main unit	-
3/8" Charging hose 152cm blue x 1 pce	Y27860
3/8" Charging hose 152cm red x 1 pce	Y28060
Adapter for different diameter 5/16" female x 3/8" male	Y06115K
Adapter for different diameter 1/4" female x 3/8" male	Y06116K
Filter dryer 053F	ES229
3/8" Ball valve 3/8" female x 3/8" male	Y93846
Instruction manual	IM0279
Operation manual	IM0280

ECOsaver Tetra

Optional Accessories (Recovery Cylinder)

Item	Capacity	Port	Code No.
Refrigerant Recovery cylinder (with float sensor)	24L	3/8" flare	TF128
	40L		TF131
	120L		TF129

* Digital scale with overfill prevention device must be used when recovery cylinders (without float sensor) are used.

* Our original recovery cylinder should be used.

Optional Accessories (Cooling Unit)

Item	Code No.
Cooling Unit CL3	ES801

* Improves the efficiency of recovery in summer climate, recovery in large volume or recovery of R32 and R410A by using together with a recovery machine.

Optional Accessories (Other Air-Conditioning Equipment)

Item	Code No.	Note	
Vacuum Pump 4CFM	Y93549	High efficient 2-stage vacuum pump with a check valve.	
Adapter for different diameter	Y06116K	Changes the connection port from 1/4" to 3/8".	
3/8" Charging hose Plus II	183cm	The most suitable length of hose can be selected according to the condition of job site.	
	244cm		
	366cm		
	500cm		
	762cm		
	1000cm		
	1500cm		
	2200cm		
3000cm	Y14699		
Hose reel with 3/8" Charging hose Plus II	30m	XP582	Easy to carry.
3/8" Hose with ball valve (male x female)	15cm	Y26202	Prevents from discharging refrigerant when the hose is removed.
Solenoid valve opener	ES705	Opens a solenoid valve forcibly. Applicable size : ϕ 10mm · ϕ 12.5mm · ϕ 15mm · ϕ 18mm.	

ECO saver Tetra

HOW TO USE

Preparation before Operation

1) Environment of Usage

- “Transportation” and “Evacuation of the air in the cylinder” should be done in view of the following environment of usage.

- ① Do not use the machine in rain or in areas where water may enter into the machine.

A fan is built into the machine for cooling and it may suck water.

- ② The recovery machine should be used in a well-ventilated area.

When the machine is used in a poor ventilated area, you may be choked from lack of oxygen in case of refrigerant leak.

- ③ Keep fire away to prevent phosgene (highly toxic substance) being generated.

- ④ Combustible gases (hydrocarbon system) cannot be recovered.

If any combustible gases [ammonia, hydrocarbon (propane, isobutene) and so on] enter into the recovery machine, it may catch fire and may explode.

- Please note the following points before use.

- ① Evacuate the air from the refrigerant recovery machine, charging hoses and recovery cylinder (hereinafter called recovery machine, hoses and cylinder).

- ② Install a filter or a filter dryer at the suction port of the recovery machine.

- ③ Close the suction valve before starting the recovery machine.

- ④ Abnormal noise may be heard when large amount of liquid refrigerant enters into the compressor.

Throttle the suction valve until the noise cannot be heard.

- ⑤ Do not close the discharge valve or the valve of the cylinder before stopping the recovery machine during operation.

The discharge gauge may be damaged.

Close the valve on the manifold, stop the recovery machine and then close the valves at the discharge (high pressure) side.

- ⑥ The temperature of the cylinder may rise when the ambient temperature is high or R410A is recovered.

Lower the temperature and pressure of the cylinder according to “page 10 4) Helpful Information” and “page 15 Recovery Procedure of R410A or When the Pressure of Refrigerant is High” .

- ⑦ Do not enter the air into the hoses and the cylinder.

When the cylinder contains air, evacuate the air from the vapor valve referring to the chart of saturation temperature and pressure.

The air can be evacuated before discharging the refrigerant.

- ⑧ Use an oil separator when refrigerant with a large amount of oil is recovered.

The compressor may be damaged when a large amount of oil is recovered.

- ⑨ Do not recover virgin refrigerant.

The compressor may be damaged if virgin refrigerant is recovered for a long time.

If you need to recover virgin refrigerant, put some additional oil in the compressor.

- ⑩ Do not recover from air conditioners in which any sealant has ever been charged.

The sealant may clog the valves or the compressor and the recovery machine may be damaged.

- ⑪ Do not evacuate the air from the cylinder by using the recovery machine.

The compressor may be damaged if it is run for a long time under vacuum.

- ⑫ Do not leave refrigerant in the recovery machine.

Always open the suction port and the discharge port when the recover machine is stored.

2) Transportation

- All connections between the recovery machine and the cylinder should be disconnected during transportation.

⚠ CAUTION



- ◆ All connections between the recovery machine and the cylinder should be disconnected during transportation.
- ◆ Steer clear of injuries when you carry a heavy cylinder.

ECOsaver Tetra

3) Cylinder

- Use our original recovery cylinders.
- Use cylinders on which the type of refrigerant to be recovered is mentioned.
- Empty cylinders should be evacuated before use.

⚠ CAUTION



- ◆ The cylinder is designed according to the specifications of the recovery machine. The cylinder may be overfilled and exploded if the appropriate cylinder is not used.

- How to evacuate air (Vacuum pump is optional)

⚠ CAUTION



- ◆ Brand-new cylinders have nitrogen inside. Evacuation should be done after discharging nitrogen by opening the vapor valve.
- ◆ Do not evacuate air from cylinders which contain refrigerant. The refrigerant will be discharged to the air and the vacuum pump oil will blow out.
- ◆ Do not evacuate air from cylinders by using the recovery machine. The compressor may be damaged if it is run for a long time under vacuum.

- ① Connect the suction port of the vacuum pump to the vapor port of the cylinder with a hose.
- ② Switch on the vacuum pump.
- ③ Close the liquid port of the cylinder and open the vapor port.
- ④ Close the vapor port of the cylinder when the vacuum reaches -0.095 to -0.1 MPa.
- ⑤ Switch off the vacuum pump.
- ⑥ Disconnect the hose between the vacuum pump and the cylinder.

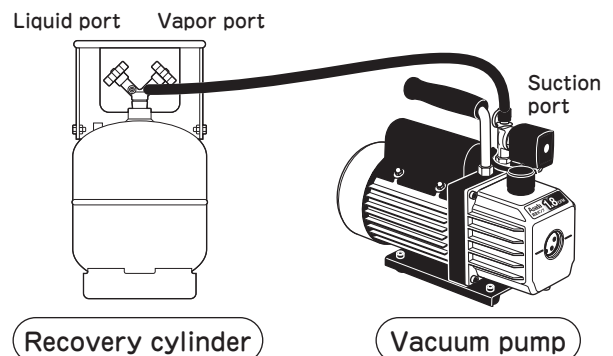

4) Helpful Information

- How to shorten the recovery time

① How to avoid rise in pressure in the cylinder (recovery in summer / efficient setup)

- Put the recovery machine in a well-ventilated shady area.
- Do not put the recovery machine and the cylinder directly on the floor but approximately 1m above the floor.
- Prepare some spare cylinders in the shade.
- Send air to the condenser of the recovery machine by an electric fan and so on to improve the efficiency.
- Cool the cylinder with wet cloths.
- Send air to the cylinder by an electric fan and so on to cool it down.
- Use a Cooling Unit or follow the sub-cooling procedure.
- Recover in liquid as much as possible.
- Throttle the suction valve not to increase the discharge pressure too much.

② How to prevent efficiency reduction due to the pressure drop in the system (low temperature, condensed to liquid / efficient setup)

- What to do when the temperature and pressure of the cylinder rise

- ① Use Cooling Unit (optional accessory). (See page 15.)
- ② Throttle the suction valve to reduce the suction pressure. (See page 15.)
- ③ Replace the cylinder with an empty one.
- ④ Cool the cylinder with the sub-cooling procedure.
- ⑤ Use a 120L cylinder.

- After recovery in liquid, recover from both the liquid and the vapor ports.
- Keep applying current to the crankcase heater of the system.
- Heat up and vibrate the accumulator and so on when they are frosted.
- Suspend recovery operation and wait for pressure increase if the recovery speed is slow when the suction pressure is around 0.1MPa.
- Connect to multiple systems at a time to reduce the effect of low temperature condensation.
- When the vertical piping is long, recover from the bottom of piping or heat up and vibrate the bottom of piping to speed up evaporation.

③ Eliminate the causes which obstruct the refrigerant flow.

- Remove the core depressor in the hose.
- Use hoses with larger diameter.
- Replace the gasket of hose if it is deformed.

ECO saver Tetra

Standard Recovery Procedure

1) Connection of the hoses and cords

- This recovery method is the most basic and popular method.
Do not try other methods (Push/Pull recovery and so on) unless you master this method.

When a cylinder with float sensor is used

When a cylinder without float sensor is used

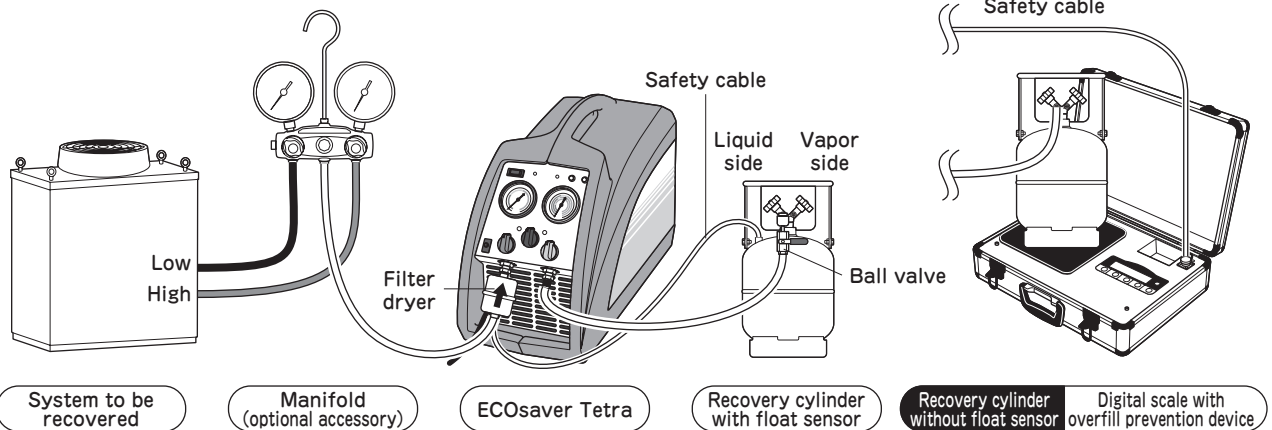

- ① Connect the hoses as above.

CAUTION



- ◆ Use Digital scale with overfill prevention device when a cylinder without float sensor is used.

- ② Connect the safety cable to the connector on the cylinder or on Digital scale with overfill prevention device.

CAUTION



- ◆ The recovery machine will not start without connecting the safety cable.

- ③ Install a filter dryer 053F (Code No. ES229) to the suction port of the recovery machine.

CAUTION



- ◆ Make sure the installing direction.
- ◆ Replace the filter dryer every recovery of 90kg or when it is clogged.

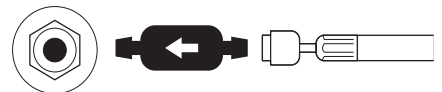

ECO saver Tetra

2) Evacuation of the air from the recovery machine and the hoses

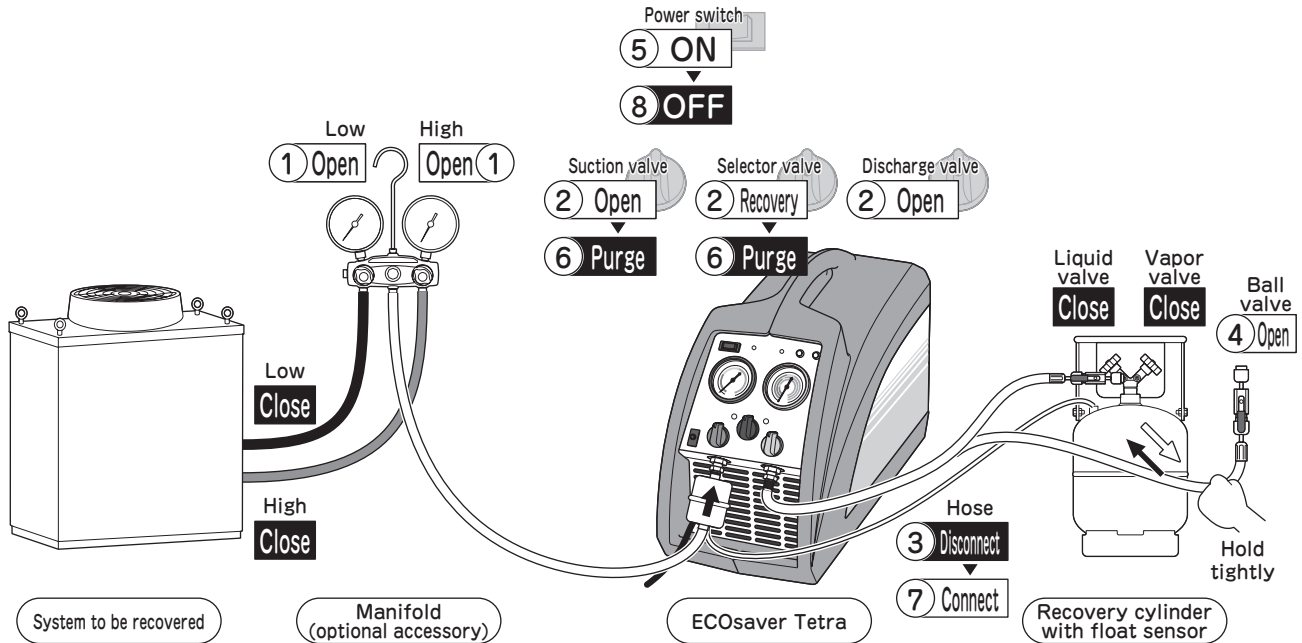

Valve operation

- ① Open the low pressure side and the high pressure side valves of the manifold.
- ② Set the suction valve of the recovery machine to the “Open” position.
Set the selector valve to the “Recovery” position.
Set the discharge valve to the “Open” position.
- ③ Disconnect the hose connected to the liquid port of the cylinder.
* Hold the hose tightly.
- ④ Open the ball valve of the hose.

Operation

- ⑤ Switch on the recovery machine.
- ⑥ When the discharge pressure reaches to a vacuum,
set the suction valve to the “Purge” position.
Set the selector valve to the “Purge” position.
- ⑦ When the discharge pressure reaches to a vacuum again,
connect the hose to the liquid port of the cylinder.

End of operation

- ⑧ Switch off the recovery machine.

ECOsaver Tetra

3) Recovery procedure

- Recover from the high pressure side of the system in case of liquid recovery and recover from the low pressure side in case of vapor recovery.
- Use a cylinder whose port size is 3/8" or more.

⚠ CAUTION

Please note the following points as this machine is a high speed recovery machine.

Voltage Drop



- ◆ Avoid voltage drop as this recovery machine is 220-240V 750W and the starting current is large. The recovery machine may stop if the voltage drops.
- ◆ Use a step-up transformer or a generator if the voltage drops considerably.
- ◆ An extension cord used should be with a length of 10m or less when its wire diameter is 1.25mm² or with a length of 20m or less when its wire diameter is 2.0mm².
- ◆ Do not use an extension cord wrapped on a reel. If the cord is used with wrapped on a reel, the cord may be overheated and melt.

Liquid Recovery



- ◆ If a 24L cylinder is used, the recovery machine may stop suddenly due to rapid pressure increase. Replace the cylinder with an empty one.
- Use a 40L or 120L cylinder.
- Throttle the valve to regulate the pressure at the suction port to 0.3MPa or less.

Vapor Recovery



- ◆ The pressure and the temperature in the cylinder will rise when the ambient temperature is high like in summer. Regulate the discharge pressure of the recovery machine according to the following chart.
- Use Cooling Unit CL3.
- Cool the cylinder.
- Replace the cylinder with an empty one.
- Throttle the valve to regulate the pressure at the suction port to 0.3MPa or less.
- * See page ○○ for details.

Refrigerant	Discharge Pressure
R12、 R134a	1.3MPa
R22、 R407C	2.1MPa
R410A	2.9MPa

Discharge Pressure



- ◆ Regulate the pressure so that the needle of the discharge gauge will not go in the red zone.
- * If the operation is continued in the red zone, the safety valve (fusible plug) will operate and the refrigerant will be discharged.

Discharge pressure gauge

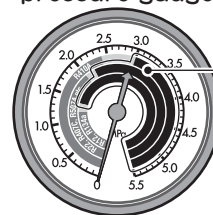

Cylinder



- ◆ Use a large volume cylinder with valves whose port size is 3/8" or more.
- * Do not use a cylinder with valves whose port size is 1/4". Otherwise the recovery machine may stop frequently and be damaged.

ECO saver Tetra

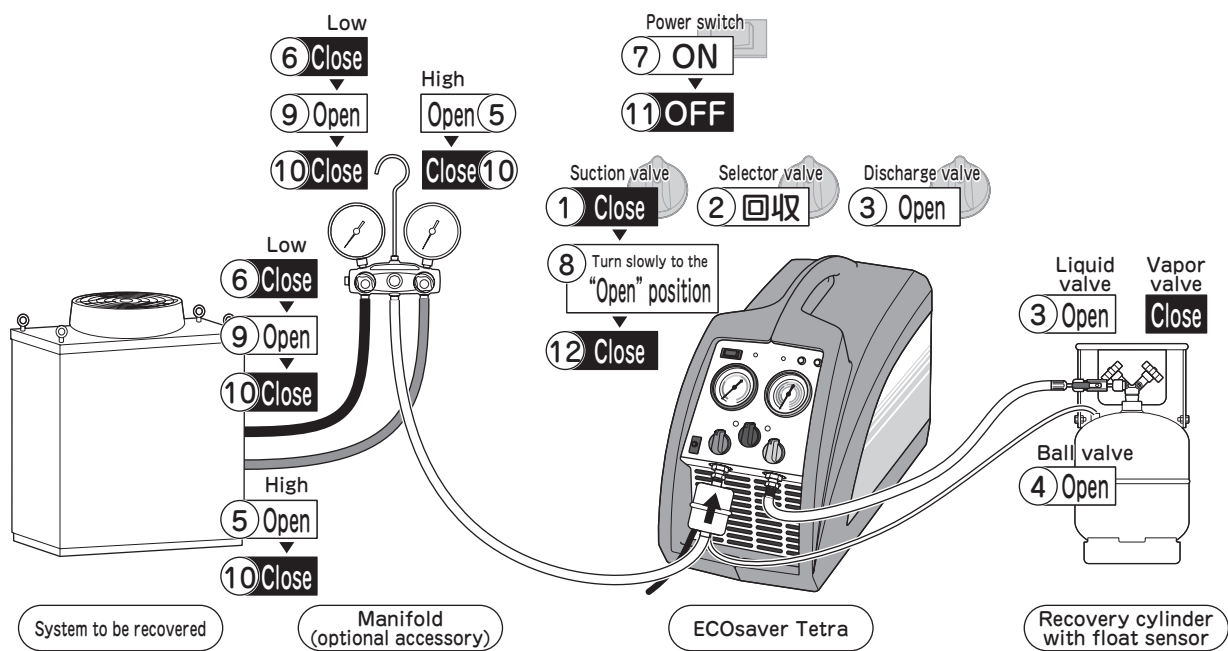

HOW TO USE

Valve operation

- ① Set the suction valve of the recovery machine to the “Close” position.
- ② Set the selector valve to the “Recovery” position.
- ③ Set the discharge valve to “Open” and open the liquid valve of the cylinder.
- ④ Open the ball valve of the hose of the discharge side.
- ⑤ Open the valve of the high pressure side of the manifold and open the port of the high pressure side of the system to be recovered.
- ⑥ Close the valve of the low pressure side of the manifold and close the port of the low pressure side of the system to be recovered.

Operation

- ⑦ Switch on the recovery machine.
- ⑧ Turn the suction valve of the recovery machine slowly to the “Open” position.
- ⑨ When liquid recovery is completed and vapor recovery starts, open the valve of the low pressure side of the manifold and open the port of the low pressure side of the system to be recovered.

End of operation

- ⑩ When the pressure of the low pressure side reaches to a vacuum, close both the low and the high pressure side ports of the system as well as both the high and the low pressure side valves of the manifold.
- ⑪ Switch off the recovery machine.
- ⑫ Set the suction valve of the recovery machine to the “Close” position.

Concerning the end of operation . . .
 After the recovery operation, leave the system for 5 to 10 minutes to see if the refrigerant melted in the refrigeration oil will evaporate.
 If the pressure rises from a vacuum, repeat the recovery operation.

ECO saver Tetra

Recovery procedure for R410A or when the pressure of refrigerant is high

- Follow the following procedure when R410A or refrigerant at high pressure by heat is recovered.

⚠ CAUTION



- ◆ Noncondensable substance (air) may exist in the cylinder when the temperature of the cylinder rises abnormally during recovery.
Remove the air or replace the cylinder.

■ Regulate the suction pressure

- Reduce the suction pressure when R410A is recovered at high ambient temperature.

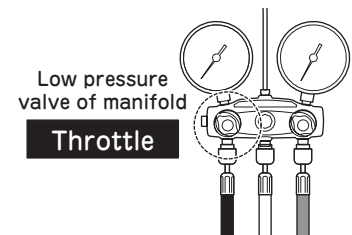

■ Cool down the cylinder (Sub-cooling)

- The following procedure is to cool down (sub-cool) the refrigerant in the cylinder instead of putting the cylinder in water.

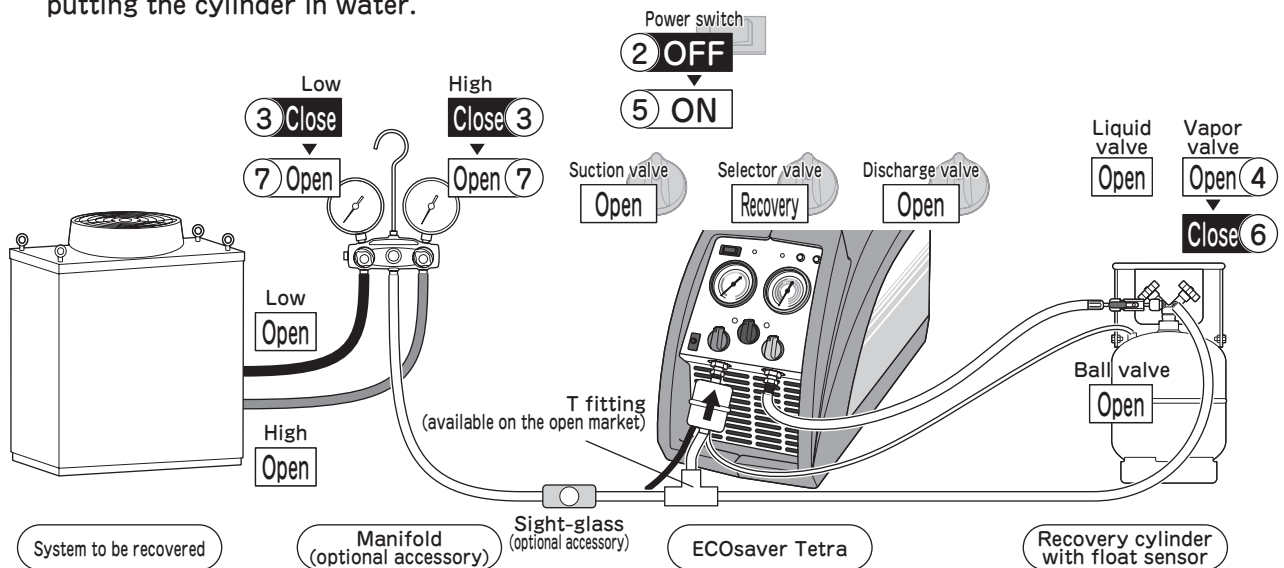

- ① Connect the hoses as above and recover refrigerant.
- ② Switch off the recovery machine when the temperature and the pressure in the cylinder rise.
- ③ Close both the high and the low pressure side valves of the manifold.
- ④ Open the vapor valve of the cylinder.
- ⑤ Set the Power switch of the recovery machine to the "ON" position.
- ⑥ Close the vapor valve of the cylinder when the pressure in the cylinder drops.
- ⑦ Open the high pressure side valve or the low pressure side valve of the manifold and continue recovery.

■ Use Cooling Unit CL3 (optional accessory)

- Cooling Unit (Code No. ES801) can lower the temperature of refrigerant at high pressure.
Improves the recovery rate up to 20% by cooling refrigerant.
See the instruction manual of Cooling Unit for detailed information.

■ Replacement of spare cylinder

- Use an evacuated spare cylinder.

ECO saver Tetra

4) Refrigerant clearing (Purge) procedure

⚠ CAUTION



- ◆ Always perform the purge procedure after completing recovery.
The recovery machine may be damaged if any refrigerant is left in the machine.

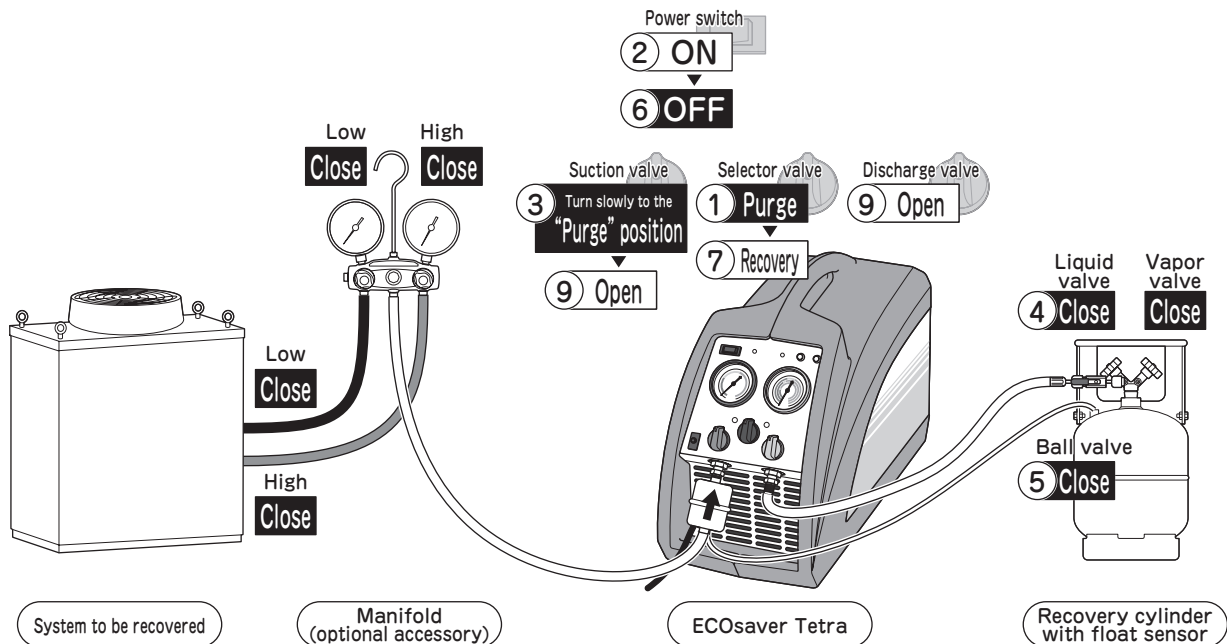

Valve operation

- ① Set the selector valve of the recovery machine to the “Purge” position.
- * Do not turn the selector valve during operation.
Otherwise the discharge pressure gauge may be damaged.

Operation

- ② Switch on the recovery machine.
- ③ Turn the suction valve of the recovery machine slowly to the “Purge” position.
- ④ Close the liquid port of the cylinder when the suction pressure gauge indicates vacuum.
- ⑤ Close the ball valve of the hose at the discharge side.

End of operation

- ⑥ Switch off the recovery machine.
- * There is vapor refrigerant left in the recovery machine and the hose of the discharge side.
Connect the hose of the discharge side to an evacuated cylinder to recover the refrigerant left in the recovery machine and the hose.
- ⑦ Turn the selector valve to the “Recovery” position.
 - ⑧ Disconnect the hoses.
 - ⑨ The suction valve and the discharge valve should be set to the “Open” position when the recovery machine is stored.

⚠ CAUTION



- ◆ Wear protective goggles and rubber (leather) gloves as a minute amount of refrigerant is discharged.
If refrigerant falls in your eyes or touches your skin, it may lead to sight loss or cold injury.

ECO saver Tetra

Push/Pull Recovery Procedure

- This method is recommended for recovery from a system which has a large amount of refrigerant (20kg or more).
- Recovery time can be reduced by recovering the liquid refrigerant in the system to the cylinder and then recovering the remaining refrigerant in vapor.
- This method cannot be applied to the following systems.
 - Refrigeration and air-conditioning systems whose refrigerant volume is less than 20kg.
 - Systems which have a heat pump or a solenoid valve.
 - Systems which have an accumulator.
- There are some other cases to which this method cannot be applied.
Ask the manufacturer of the system if not clear.

1) Connection of the hoses and cords

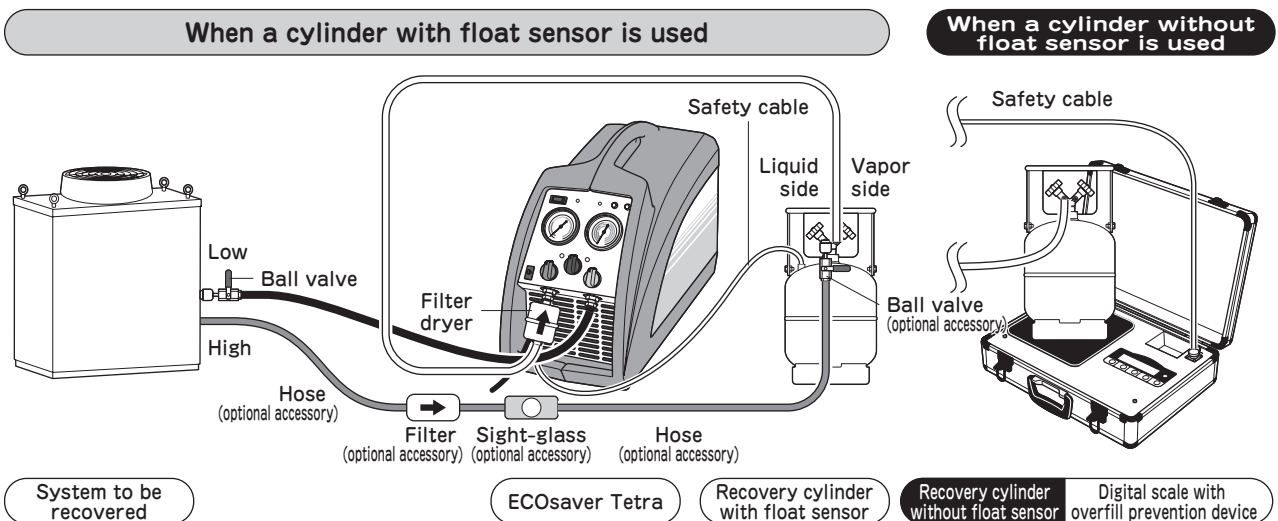

- ① Connect the hoses as above.

⚠ CAUTION



- ◆ Use Digital scale with overfill prevention device when a cylinder without float sensor is used.

* It is easy to change the hose connection after Push/Pull recovery if a 3/8" ball valve is installed at the hose end.

- ② Connect the safety cable to the connector on the cylinder or on Limit Scale.

⚠ CAUTION



- ◆ The recovery machine will not start without connecting the safety cable.

ECO saver Tetra

2) Evacuation of the air from the recovery machine and the hoses

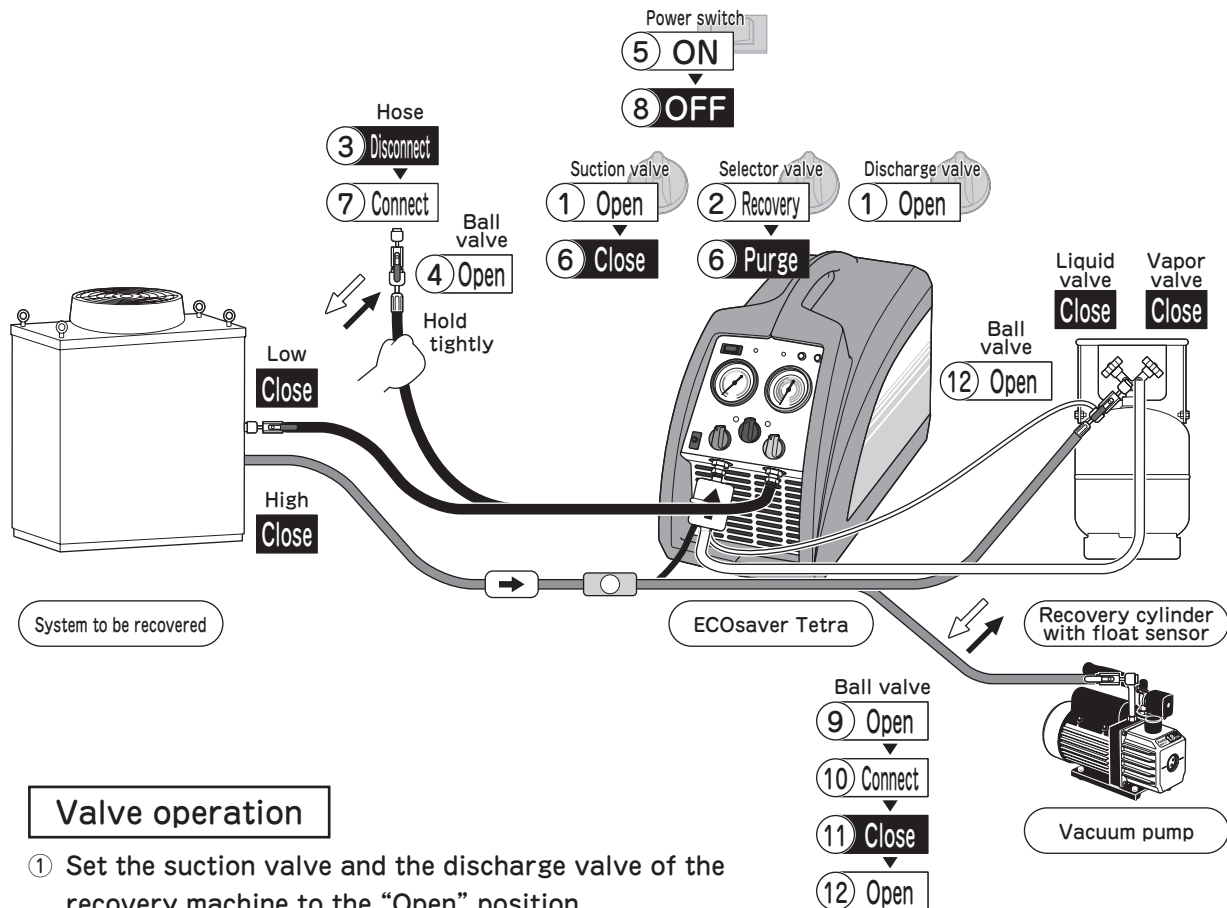

Valve operation

- 1 Set the suction valve and the discharge valve of the recovery machine to the "Open" position.
- 2 Set the selector valve to the "Recovery" position.
- 3 Disconnect the hose connected to the low pressure side of the system to be recovered.
* Hold the hose tightly.
- 4 Open the ball valve of the hose.

Operation

- 5 Switch on the recovery machine.
- 6 When the suction pressure reaches to a vacuum, set the suction valve to the "Close" position. Set the selector valve to the "Purge" position.
- 7 When the discharge pressure reaches to a vacuum again, connect the hose to the low pressure side of the system.

End of operation

- 8 Switch off the recovery machine.
- 9 Open the ball valve of the hose connected to the cylinder.
- 10 Connect the hose to a vacuum pump and evacuate the air from the hose.
- 11 Close the ball valve of the hose.
- 12 Connect the hose to the liquid port of the cylinder and open the ball valve.

ECOsaver Tetra

3) Recovery procedure

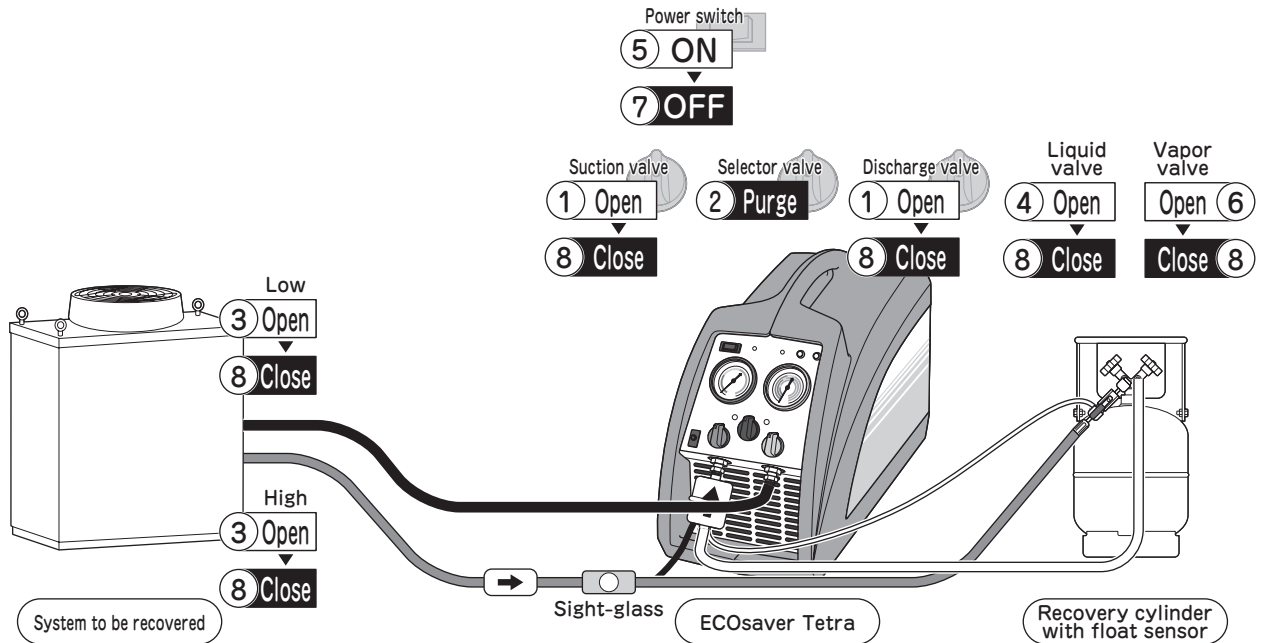

Valve operation

- ① Set the suction valve and the discharge valve of the recovery machine to the “Open” position.
- ② Set the selector valve to the “Purge” position.

Operation

- ③ Open both valves of the high pressure side and the low pressure side of the system to be recovered.
- ④ Open the liquid valve of the cylinder.
- ⑤ Switch on the recovery machine.
- ⑥ Open the vapor valve of the cylinder slowly.

End of Push/Pull recovery

- ⑦ Switch off the recovery machine when liquid recovery is completed.
- * Make sure that there is no liquid flow in the sight-glass.
- ⑧ Close all valves.
- ⑨ Change the connection of the hoses and perform vapor recovery according to “Standard Recovery Procedure” as there is still some vapor refrigerant in the system.

⚠ CAUTION



- ◆ Wear protective goggles and rubber (leather) gloves as a minute amount of refrigerant is discharged. If refrigerant falls in your eyes or touches your skin, it may lead to sight loss or cold injury.
- ◆ In case of Push/pull recovery, use a scale to check the amount of refrigerant recovered. When the cylinder is full, refrigerant may be recovered continuously even after the recovery machine stops and may lead to overfilling.

ECOsaver Tetra

Pressure Balancing between the Recovery Machine and the Cylinder

● Follow this procedure when the difference of the pressure between the low pressure side and the high pressure side in the recovery machine is too large in case a cylinder containing refrigerant is used, in case the recovery machine stopped by the high pressure switch, or in case the recovery machine is stopped during operation (also in case the motor is overloaded when starting) for pressure balancing in the recovery machine.

- ① Set the suction valve of the recovery machine to the “Purge” position.
- ② Set the suction valve to the “Close” position after checking the pressure rises on the suction pressure gauge.
- ③ Switch on the recovery machine.
- ④ Set the suction valve to the “Open” position.
- ⑤ Start recovery.

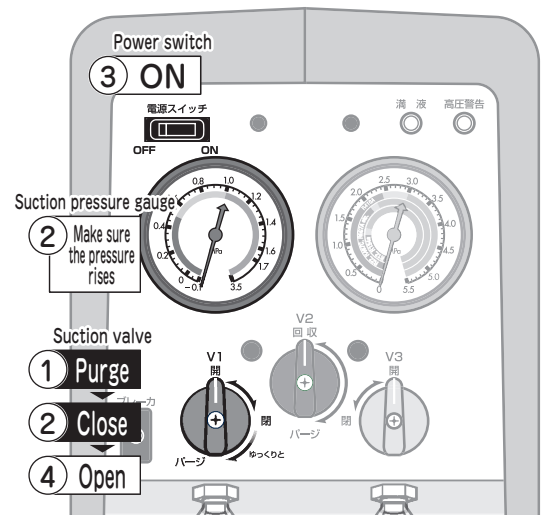

HOW TO USE

⚠ CAUTION



- ◆ The starting current is large on this recovery machine. The recovery machine may not restart even if the above procedure is performed. In that case, transfer the refrigerant in the recovery machine to an evacuated cylinder to reduce the pressure in the machine.

How to Purge Noncondensable Gases

- ① Leave the cylinder for more than 24 hours.
- ② Connect a pressure gauge to the vapor port of the cylinder to check the pressure.
- ③ Check the ambient temperature.
- ④ See the saturation temperature and pressure chart. If the actual pressure is higher than the pressure listed, noncondensable gases (air and so on) must exist in the cylinder.
- ⑤ Open the vapor port of the cylinder to discharge the noncondensable gases little by little.
- ⑥ Close the valve when the difference in pressure is within 0.04MPa compared with the pressure in the chart.
- ⑦ Leave the cylinder for 10 minutes and check the pressure again. Repeat the above procedure if needed.

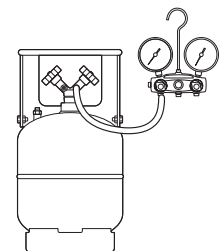

Recovery cylinder with float sensor

ECO saver Tetra

How to Recover Different Type of Refrigerant

● Follow this procedure when the different type of refrigerant is recovered.

- ① Connect the discharge port to a vacuum pump with a hose.
- ② Set the suction valve to the "Close" position.
- ③ Set the discharge valve to the "Open" position.
- ④ Switch on the vacuum pump.
- ⑤ Switch off the vacuum pump after 10 minutes.
- ⑥ Replace the filter dryer.

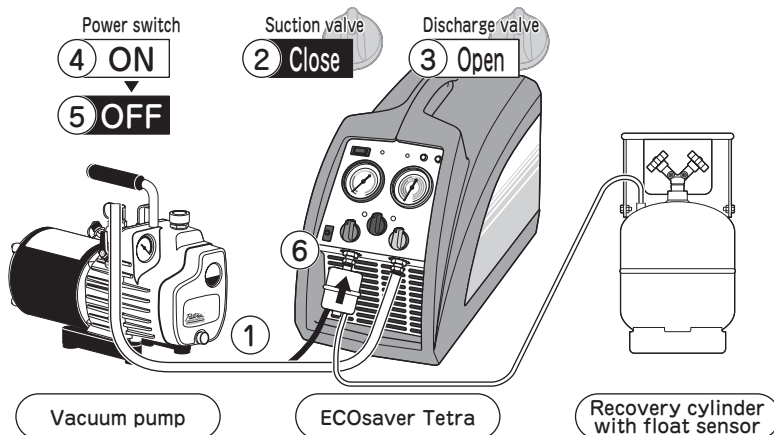

In Case the Machine Stops During Operation

1) When the recovery machine stopped by a thermal protector.

- ① The recovery machine will not start when the temperature of the motor is too high.
- ② Switch off the recovery machine and leave it for 10 to 20 minutes.
The protector will be reset when the temperature of the motor becomes lower.
- ③ Switch on the recovery machine when the temperature of the motor becomes low enough.

2) When the recovery machine stopped due to high pressure.

- ① Switch off the recovery machine.
- ② Remove the causes of the high pressure.
(Cool the cylinder by ice and so on when the temperature of the cylinder becomes 48°C or more.)
- ③ Set the suction valve to the "Close" position and then restart the recovery machine.

3) When the recovery machine stopped by a breaker.

- ① Switch off the recovery machine.
- ② Push the breaker after a while.

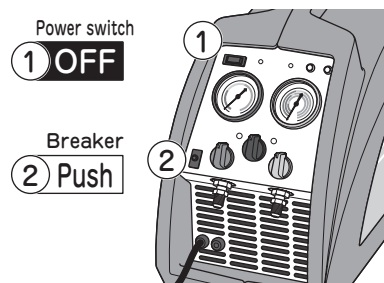

ECOsaver Tetra

RECOVERY CYLINDER

Risk of Overfilling

- Refrigerant is a high pressure gas and mistakes in use or handling will lead to a serious accident.

1) Relation between the temperature and the pressure of refrigerant in a cylinder

The pressure of the refrigerant varies depending on the ambient temperature when the refrigerant is filled in a cylinder.



At this time, lowering of the liquid level by evaporation and rising of the liquid level by specific volume increase occur at the same time and balance.



At this time, rising of the liquid level by liquefaction and lowering of the liquid level by specific volume decrease occur at the same time and balance.

The right graph shows the relation between the pressure (saturation pressure) and the temperature (saturation temperature) for each kind of refrigerant.

This relation between the saturation pressure and the saturation temperature is found when both liquid and vapor exist in a cylinder. Normally the inside of the cylinder is under this condition and this chart is useful for field operation.

When a cylinder is almost full with liquid and no vapor, the pressure rises rapidly even with a slight increase in temperature.

This phenomenon must be avoided in any circumstances.

Saturation pressure and saturation temperature of each type of refrigerant

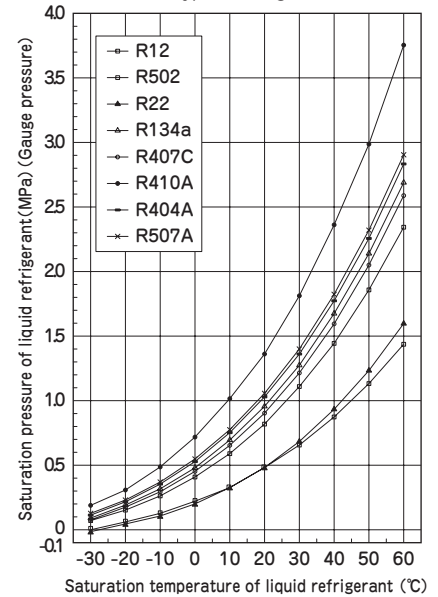

Temperature and pressure of refrigerant in cylinder

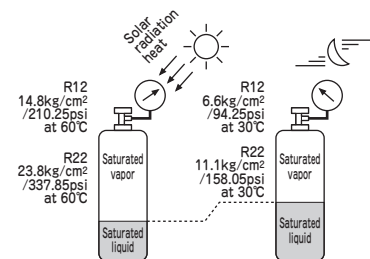

ECO saver Tetra

MAINTENANCE & INSPECTION

- Inspect and clean regularly as instructed below and perform correction or replacement timely.

Check the Cords

- ① Make sure the power plug and the power cord have no damage.
- ② Make sure the recovery machine can start after connecting the safety cable to the float sensor on the cylinder and switched on.
- ③ Make sure the recovery machine stops when the safety cable is disconnected.

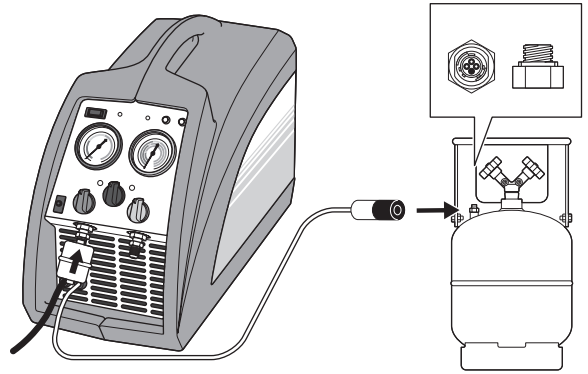

Check Refrigerant Leak

- ① Make sure there is no leak from the machine, the hoses and so on.

Check the Overfilling Prevention Function (in case a cylinder with float sensor is used)

- ① Make sure the recovery machine can start after connecting the safety cable to the float sensor on the cylinder and switched on.
- ② Make sure the recovery machine stops when the cylinder is turned upside down.

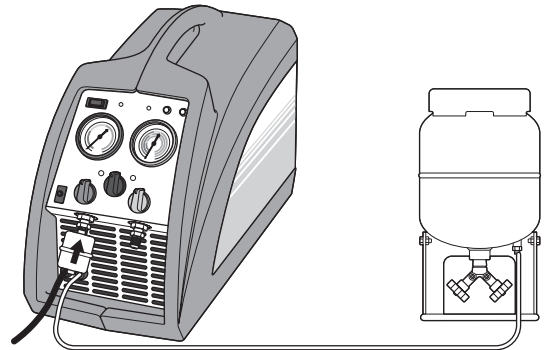

Check the Overfilling Prevention Function (in case a cylinder without float sensor is used)

- ① Make sure the recovery machine can start after connecting the safety cable to Digital scale with overfill prevention device and switched on.
- ② Make sure the recovery machine stops when the cylinder is pushed by hand to give the weight which is enough to operate the overfilling function.

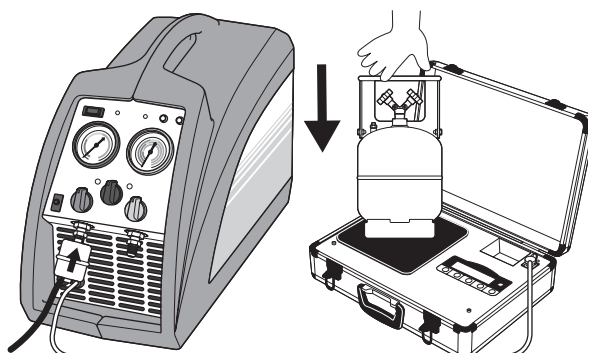

ECOsaver Tetra

Check the Recovery Function

- ① Set the suction valve of the recovery machine to the “Open” position.
- ② Set the selector valve to the “Recovery” position.
- ③ Set the discharge valve to the “Open” position.
- ④ Switch on the recovery machine.
- ⑤ Make sure the air is sucked from the suction port and discharged from the discharge port.

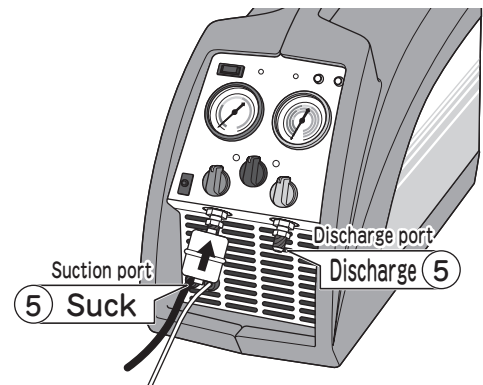

Check the Purge Function

- ① Set the suction valve of the recovery machine to the “Purge” position.
- ② Set the selector valve to the “Purge” position.
- ③ Set the discharge valve to the “Open” position.
- ④ Switch on the recovery machine.
- ⑤ Make sure the suction pressure reaches the vacuum area and the air will not be discharged from the discharge port.

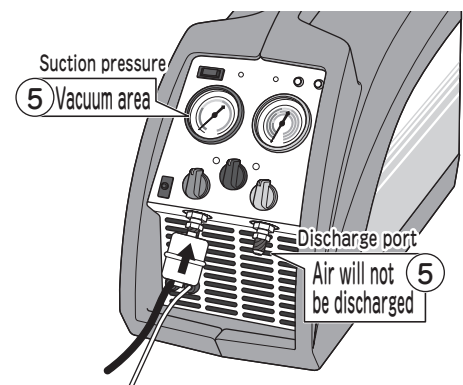

Check the High Pressure Warning Function

- ① Set the discharge valve of the recovery machine to the “Close” position.
- ② Set the suction valve to the “Open” position. Set the selector valve to the “Recover” position.
- ③ Switch on the recovery machine.
- ④ Make sure the recovery machines is stopped by the high pressure switch after a while.

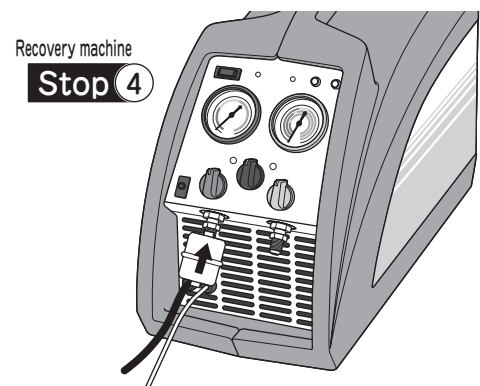

ECOsaver Tetra

BEFORE REQUESTING REPAIR OR SERVICES

Symptom	Cause	Solution
The machine will not start.	① The power cord is not plugged in.	① Plug in the power cord.
	② The safety cable is not connected.	② Connect the safety cable.
	③ The breaker tripped.	③ Reset the breaker.
	④ The machine is in high pressure shut off.	④ Reduce the pressure in the high pressure line.
	⑤ The thermal protector operated due to overheating of the motor.	⑤ Wait until the motor cools down.
	⑥ The cylinder is full.	⑥ Replace the cylinder.
	⑦ The float sensor of the cylinder is faulty.	⑦ Repair
	⑧ The motor was burned.	⑧ Repair
	⑨ The compressor is locked.	⑨ Repair
	⑩ Wiring disconnection	⑩ Repair
	⑪ The high pressure switch is faulty.	⑪ Repair
The machine stops soon after starting.	① The liquid valve of the cylinder is closed.	① Open the liquid valve of the cylinder.
	② The pressure in the cylinder is high.	② Cool down the cylinder or use Cooling Unit.
	③ The hose has a core depressor.	③ Remove the core depressor of the hose.
	④ Voltage drop.	④ Connect to a 220-240V power source.
	⑤ 1/4" hoses and a cylinder with 1/4" ports are used.	⑤ Use 3/8" hoses and a cylinder with 3/8" ports.
The recovery speed is slow or the machine will not recover.	① The built-in strainer is clogged.	① Clean or replace the built-in strainer.
	② The pressure in the cylinder is high.	② Cool down the cylinder.
	③ The piston seal is worn out.	③ Repair
	④ The cylinder valve is damaged.	④ Repair
	⑤ The hose has a core depressor.	⑤ Remove the core depressor in the hose.
	⑥ The refrigerant in the system is frozen.	⑥ Perform liquid recovery after melting.
The machine will not re-start.	① The motor is overheated.	① Wait until the motor cools down.
	② The difference in pressure between the suction side and the discharge side is too large as the pressure in the cylinder is high.	② Balance the pressure.
	③ The breaker tripped.	③ Reset the breaker.

ECO saver Tetra

ELECTRIC WIRING DIAGRAM

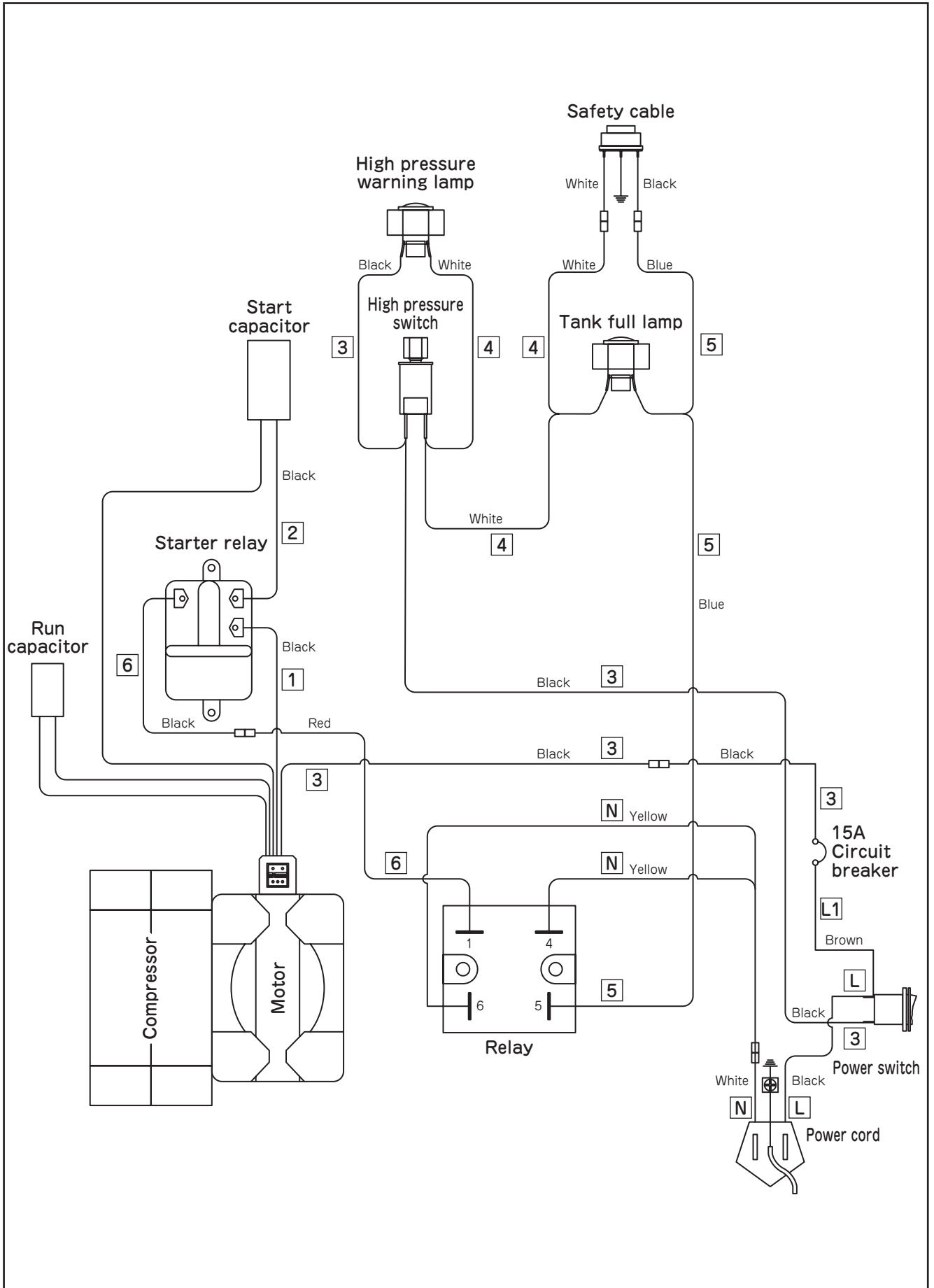

ECO saver Tetra

FLOW DIAGRAM

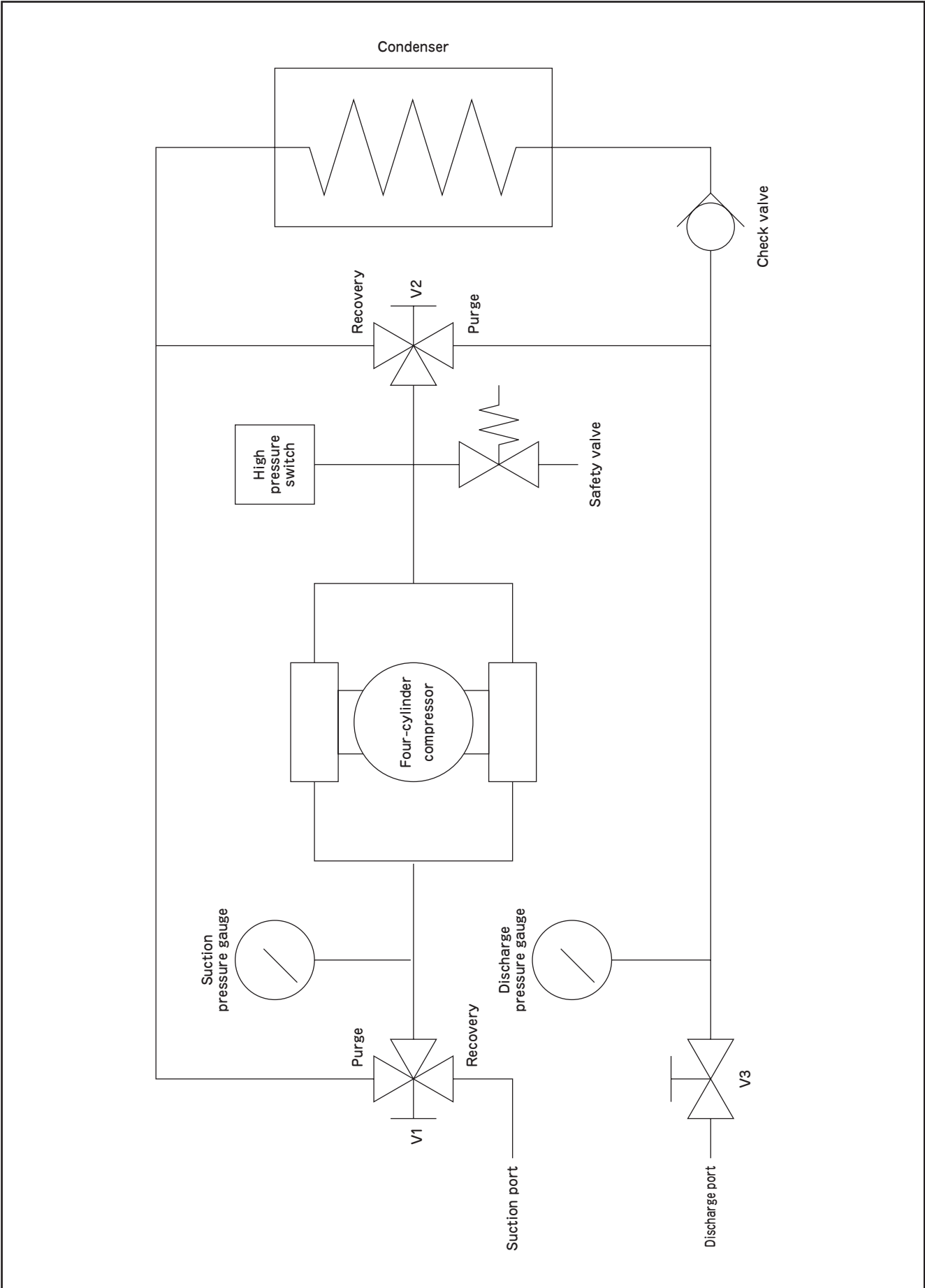

ECOsaver Tetra

ECOsaver Tetra

ECOsaver Tetra

●Customer Memo Please fill in for your record in the future
The information is helpful for inquiry and ordering parts.

Products Number:

Date Purchased:

Store Purchased the Unit:

Asada
ASADA CORPORATION

3-60, Kamiida, Nishi-Machi, Kita-Ku, Nagoya, Japan 462-8551

TEL +81-52-914-1062

FAX +81-52-914-1144

URL <http://www.asada.co.jp>

E-mail: trade@asada.co.jp