

# Asada

Large Diameter Existing Pipe Cutting Machine (Air Motor Operated)

# PIPE SAW 400SA

## INSTRUCTION MANUAL

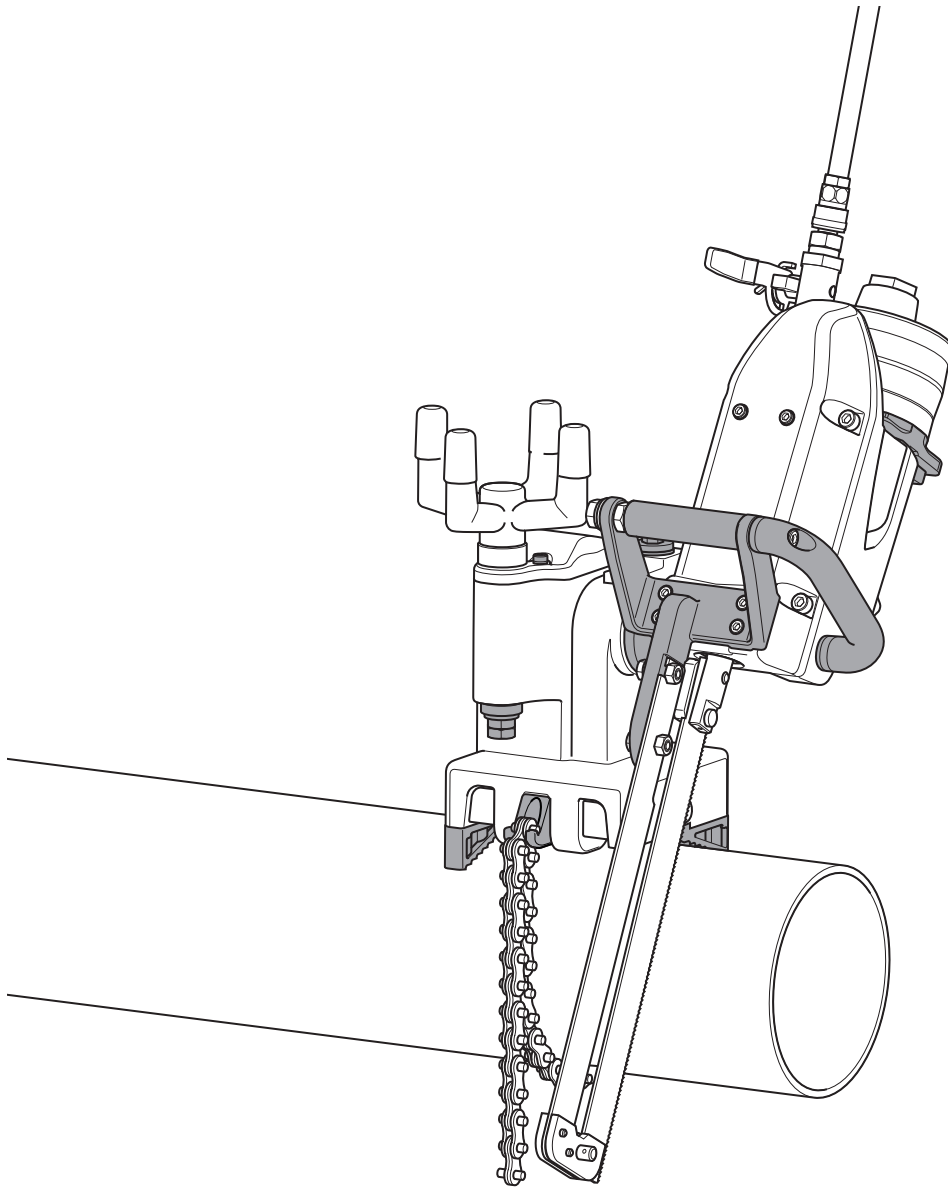

**[Read through this manual carefully before using the machine.]**

# PIPE SAW 400SA

## SAFETY PRECAUTIONS

Thank you for choosing the PIPE SAW 400SA.

- This manual should be handed over to the end user.
- The content of this manual must be thoroughly read and understood securely before operation.
- Please save this manual for immediate reference when required.
- Use the machine for the intended application only.

This machine is designed to cut existing pipes of steel, stainless steel, PVC, etc.



- Check the following as soon the machine is delivered:
  - Is the specification same as the ordered product?
  - Is there any damage or deformation caused during delivery transit ?
  - Is there any shortage of accessories ?

If any dissatisfaction is found, please contact with the store you have purchased or our sales department.

(The contents of instruction manual will be changed without notice for quality improvement.)

## CLASSIFICATION OF CAUTIONS

In this manual and on the machine, the safety instruction levels are classified into as following three levels.

	Denotes that incorrect handling would cause immediate death or injury to the user and others.
	Denotes that incorrect handling can cause death or injury to the user and others.
	Denotes that incorrect handling can cause user injury or physical damage.

## CONTENTS

SAFETY INSTRUCTIONS .....	2	OPERATION .....	11
OPERATING INSTRUCTIONS .....	5	Fixing the vise .....	11
COMPONENTS OF THE MACHINE .....	7	How to set the main body .....	13
Name of Parts .....	7	How to set the saw blade .....	13
Specifications .....	8	How to set the guide plate .....	14
Standard Accessories .....	8	Installation of Air Maintenance Unit and Air Compressor ...	14
Optional Accessories .....	9	Cutting .....	15
PREPARATIONS .....	10	Cutting the buried pipe .....	18
Carrying the Machine .....	10	Cutting the vertical pipe .....	19
Maintaining and Checking the Working Environment .....	10	CLEANING THE PARTS .....	20
		MAINTENANCE & INSPECTION .....	21
		TROUBLESHOOTING .....	22

# PIPE SAW 400SA

## SAFETY INSTRUCTIONS

- To prevent accidents such as fire, electrical shock and injury, always follow the "SAFETY INSTRUCTIONS" described below.
- Before using the machine, read all "SAFETY INSTRUCTIONS" to use it correctly according to the instructions.
- After reading the instructions, save this manual so that you can read it when necessary.

### WARNING

#### ◆ **Avoid dangerous environment.**

Do not expose the machine to rain or water and do not use it in damp or wet locations. Humidity will deteriorate motor insulation or lead to electrical shock.

#### ◆ **Use safety goggles.**

Wear safety goggles while operating the machine. Also use a face or dust mask if operation creates dust. Sawdust and dirt may enter your eyes and nose.

#### ◆ **Secure work piece.**

Use clamps or a vise as described in the manual to hold a workpiece securely.  
An insecure workpiece will lead to accident or injury.

#### ◆ **Use only the specified accessories and attachments.**

Use only the accessories and attachments given in this manual and our catalogs.  
A failure to do so will lead to accident or injury.

#### ◆ **Never touch the saw blade and moving parts until you have confirmed a complete stop.**

When it is required to touch the saw blade or moving parts for replacement, etc., switch off the machine and unplug it before starting.  
If the machine remains plugged in, it may start suddenly, leading to an accident or injury.

#### ◆ **Remove Air Hose from the machine after stopping Air Compressor and closing Ball Valve of the unit in following the cases.**

- When not in use or when servicing, cleaning, checking or replacing parts.
- When replacing accessories such as saw blade.
- When hazard is predictable (including a power failure).

If Air Hose remains connected to the machine, it may start suddenly, leading to a serious injury.

#### ◆ **If you feel something unusual, stop the machine immediately.**

Immediately stop the machine if something is wrong with the machine or you have noticed unusual smell, vibration, sound etc. during operation. Refer to page 22 "TROUBLESHOOTING" in this manual and follow the corresponding instructions.

If you use the machine without taking any action, it will overheat, emit smoke or take fire, leading to accident or injury.

#### ◆ **Keep your work area clean.**

Keep your work bench and area tidy and well.  
Cluttered area and bench invite injury.

# PIPE SAW 400SA

## WARNING

### ◆ **Keep visitors away.**

Do not let visitors touch the machine and air hose or operate the machine.  
All visitors, especially children, should be kept away from the work area to avoid injury.

### ◆ **Do not force the machine.**

Use the machine for the intended application only.  
It will do a better job and be safer at the rate for which it was designed.  
Forcing the machine will not only invite product damage but also lead to accidents.  
Avoid forcible usage which will cause the motor to lock. A smoke or fire may occur.

### ◆ **Wear proper apparel.**

Do not wear neckties, open-sleeved clothing, knitted gloves, loose clothing or jewelry (such as necklaces). Otherwise you may get caught in moving parts.  
Rubber gloves and non-skid footwear are recommended when working in outdoors.  
Slippery gloves and footwear will lead to injury.  
Wear caps or protective hair covering to contain long hair.  
Wear crash helmets, safety shoes, etc. according to your working environment.

### ◆ **Do not overreach.**

Keep proper footing and balance at all times. You may tumble and get hurt.

### ◆ **Remove wrenches and other hand tools.**

Before turning on the machine, make sure that hand tools used for the inspection or adjustment have been removed from the machine.  
Accident or injury may occur if you start the machine with hand tools on it.

### ◆ **Stay alert.**

Watch what you are doing and use common sense while working.  
Carelessness will lead to accident or injury.  
Do not operate the machine when you cannot concentrate on your work, e.g. when you are tired or while under the influence of alcohol, medication or drugs. Otherwise, accident or injury may occur.

### ◆ **Do not abuse the air hose.**

Never carry the machine by Air Hose or pull it to disconnect from Air Maintenance Unit or Air Compressor.  
Keep Air Hose away from heat, oil, grease, knives or things having sharp edges.  
Place the machine in where Air Hose will not be stepped on, hooked, or damaged by excessive force. Otherwise, you may get electrical shock or the cord may be shorted causing a fire.

# PIPE SAW 400SA

## WARNING

### ◆ **Maintain the machine with care.**

Keep the saw blade sharp and clean for better and safer performance.

If the saw blade used is worn, damaged or improper for an intended purpose, the motor and machine will be overloaded. This may cause the machine to generate heat, emit smoke or cause fire, or you may get injured.

Follow instructions for replacing accessories.

Inspect the power cord and plug before use. If damaged, have them repaired by our sales representative.

Otherwise you may get electrical shock or the machine may be shorted to cause fire.

Keep handles dry, clean and free from oil and grease, which may lead to injury.

### ◆ **Check damaged parts.**

Before further use of the machine, a guard or other part that is damaged should be carefully checked to determine that it will operate properly and perform its intended function.

Check the machine for alignment of moving parts, binding of moving parts, breakage of parts, mounting and any other conditions that may affect its operation.

Do not use the machine when its plug and/or cord is damaged.

You may get electrical shock or the machine may be shorted to cause fire.

Do not use the machine if its switch does not turn it on and off.

A guard or other part that is damaged should be properly repaired or replaced by an authorized service center unless otherwise indicated in this instruction manual.

### ◆ **Store the idle machine tidily.**

When not in use, machines should be stored in dry and high or locked-up place –out of reach of children.

### ◆ **Have your machine repaired by a qualified person.**

Our products are in accordance with the relevant safety rules. Do not modify them.

Repairs should only be carried out by our sales representative.

Otherwise the machine may not show its performance or you may get injured.

### ◆ **If any label applied to the machine, etc. has come off, always ask for a new label and apply it in position.**

# PIPE SAW 400SA

## OPERATING INSTRUCTIONS

- In addition to the general instruction given above, follow the precautions given below before operating the PIPE SAW 400SA.

### DANGER

- ◆ **Do not cut a pipe which contains live gas or residual gas.**  
Sparks or cutting heat from the motor can cause ignition or explosion.

### WARNING

- ◆ **Before starting operation, fully check for underground objects such as conduit pipes, water pipes and gas pipes near the place of operation.**  
If there are such objects, the saw blade may touch any of them and electrical shocks, electric leaks or gas leaks which will cause accidents may occur.
- ◆ **In case to cut a pipe with water remaining inside, avoid being splashed water onto the machine.**  
If the machine is splashed, it will lead to electrical shock.  
Water will come into the gearbox, and the gears will get damaged.
- ◆ **Hold the machine body securely during operation.**  
If you do not hold it securely, you may get injured.
- ◆ **If you have dropped or hit the machine accidentally, carefully check its saw blade, body, etc. for damage, crack or deformation.**  
Damage, crack or deformation to the saw blade or machine body will lead to accident or injury.
- ◆ **Before changing the saw blade, close Ball Valve of the unit and turn off Air Compressor.**  
Otherwise, the machine will start running suddenly, causing injury.
- ◆ **Install the saw blade to the machine correctly.**  
Otherwise, if the saw blade comes off, you may get injured.
- ◆ **Pay attention not to cut the Air Hose by the saw blade.**  
Air may jet out from the Air Hose suddenly causing a serious injury.
- ◆ **During operation, keep your hands, face, etc. Away from the saw blade and chip ejector.**  
Otherwise, you may get caught by the saw blade, causing an accident or injury.
- ◆ **Before starting operation at a high place, fully make sure that there is no one under you.**  
An accident can occur if you drop a work piece or the machine.

# PIPE SAW 400SA

## CAUTION

- ◆ **When carrying the machine, close Ball Valve of the unit and turn off Air Compressor.**  
Otherwise, the machine will run suddenly, causing an accident or injury.
- ◆ **Never touch the saw blade, chips and work piece immediately after cutting operation.**  
Immediately after cutting operation, they are hot and you can get burnt or injured.
- ◆ **When you cut a pipe near an obstacle such as a wall or an adjacent pipe, leave an enough clearance to prevent the tip of the saw blade from making contact with the obstacle.**
- ◆ **Pay attention not to cut the Air Hose by the saw blade.**  
The unit will not perform at its best due to air leakage.
- ◆ **Do not cut the work piece which requires more than capacity.**  
If cut the work piece which requires more than capacity, the saw blade may be broken.
- ◆ **Use the Asada genuine saw blade.**  
If use the other saw blade, there may be a possibility to cause accidents unexpectedly.

# PIPE SAW 400SA

## COMPONENTS OF THE MACHINE

### Name of Parts

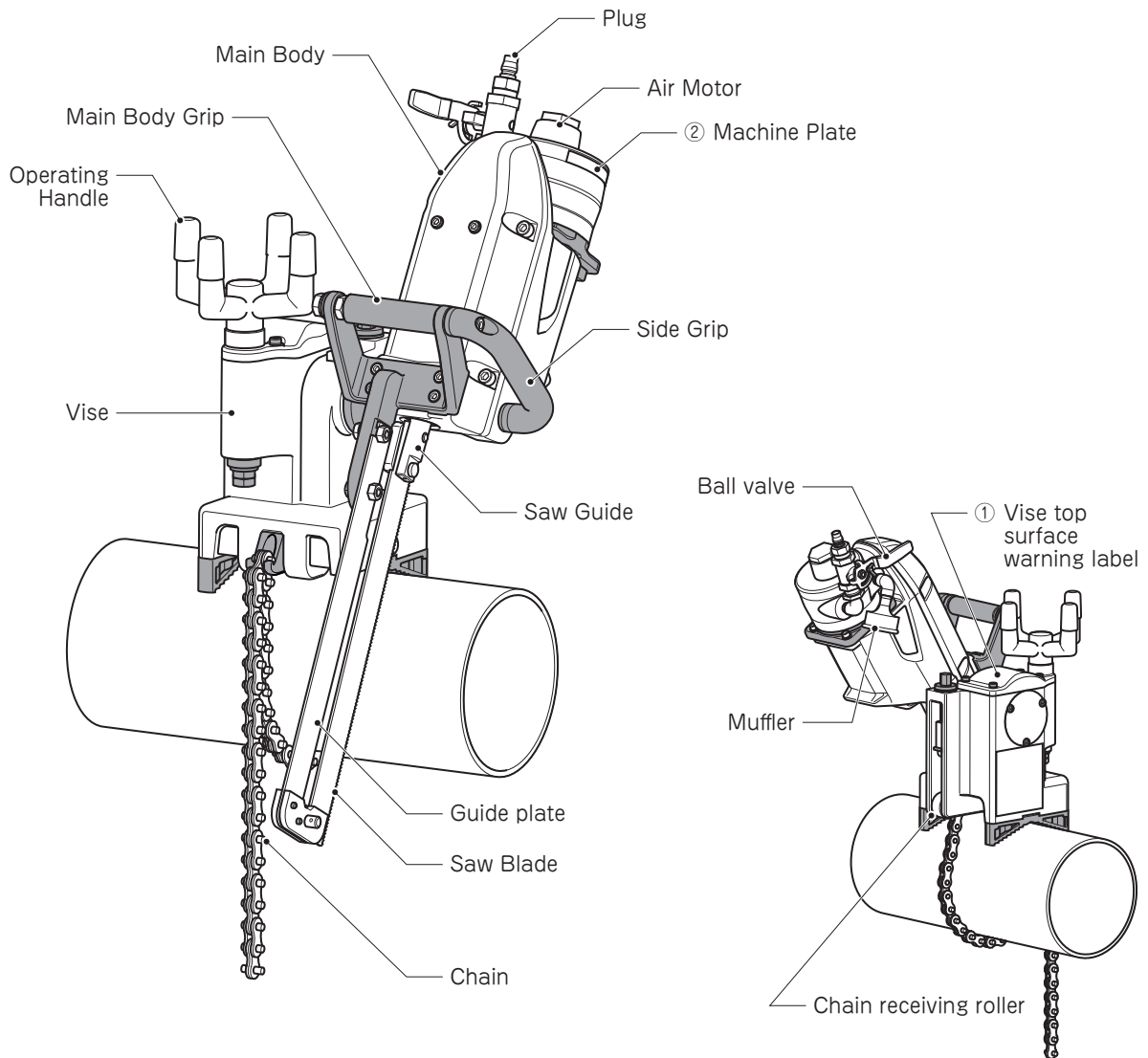

### WARNING LABEL

※ Following three warning labels are stuck to this machine and the vise.  
 These labels show explanation for securing safety.  
 Keep them clean, and if they are peeled off or became dirty, request new labels to us. Be sure to stick new label to the same place.

① Vise top surface warning label

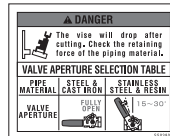

② Machine plate





# PIPE SAW 400SA

## Specifications

Description		PIPE SAW 400SA HSS
Code No.		PS401SA
Cutting Capacity	Steel pipe	1/2"~12" (thickness : 9mm or less) ※~24" with optional
	Stainless Steel pipe	1/2"~12" (thickness : 9mm or less)
Motor		Air Motor 1120W
Air Consumption		2m <sup>3</sup> /min
Stroke		57mm
No-load Stroke/Min		40~400min <sup>-1</sup> (SPM)
Weight and Size	Main Body	13kg · 480×302×252mm
	Vise	8kg · 173×210×326mm
	Plastic Box 1	3.5kg · 785×370×325mm
	Plastic Box 2	1.8kg · 420×375×330mm
Total weight (Packed state)	Plastic Box 1	30.5kg · 800×380×360mm
	Plastic Box 2	9kg · 420×375×330mm

\* Specifications will be changed without notice for quality improvement.

## Standard Accessories

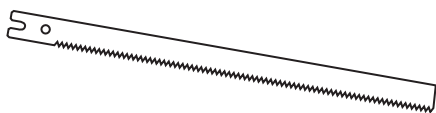

Saw blades HSS

(380×8T) 1pce

(490×8T) 1pce

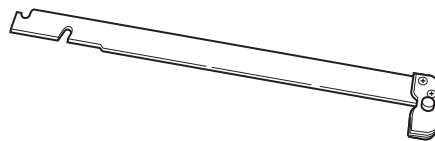

Guide plate complete for each size

(300A) 1pce

(200A) 1pce

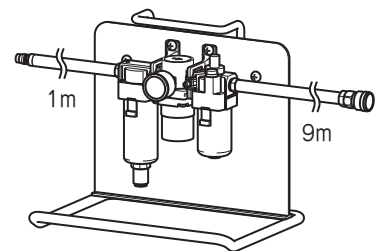

Air Maintenance Unit

(58860)

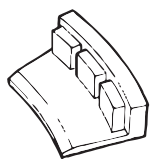

Magnet-attached wedge L

(58612)

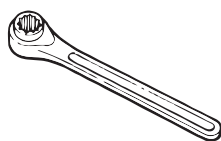

Ratchet wrench 11-13

(PS528)

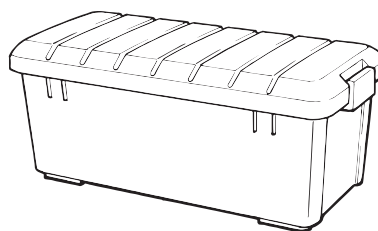

Storage box

(PS510)

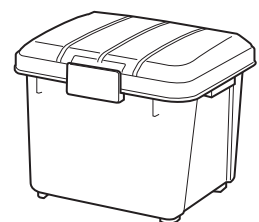

Storage box for Air Maintenance Unit

(PS565)

# PIPE SAW 400SA

## Optional Accessories

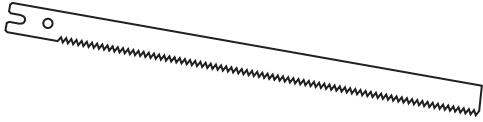

Saw blades  
(Refer to the table below.)

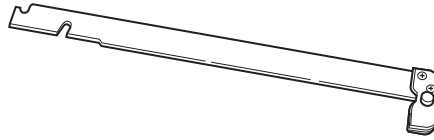

Guide plate complete for each size  
(Refer to the table below.)



Cutting Oil  
(Threading oil white)  
(ST014)

Name	Size	Cutting Capacity	Code No.	pcs/set	Remarks
Saw blade HSS	320×8T	~ 6"	70310	5pce	Casting pipe, Steel pipe
	380×8T	~ 8"	70311	5pce	
	440×8T	~ 10"	70278	5pce	
	490×8T	~ 12"	70279	5pce	
	530×8T	~ 14"	70295	5pce	
	640×8T	~ 16"	70644	5pce	
		~12"×30°			Resin pipe
815×8T	~ 24"	71099	5pce	Casting pipe, Steel pipe	
Saw blade HSS for stainless	440×8T	~ 10"	70305	5pce	Stainless Steel Pipe
	490×8T	~ 12"	70304	5pce	
Grit saw	320	~ 6"	70288	5pce	Mortared cast iron pipe
	380	~ 8"	70289	5pce	
	430	~ 10"	70260	5pce	
	480	~ 12"	70261	5pce	
	530	~ 14"	70262	5pce	
Guide plate complete	(200A)	—	PS301	1set	—
	(250A)	—	PS261	1set	
	(300A)	—	PS262	1set	
	(350A)	—	PS263	1set	
	(400A)	—	PS554	1set	
	(640)	—	PS347	1set	
	(600A)	—	PS555	1set	
Chain	(600A)	—	PS566	1set	

# PIPE SAW 400SA

## PREPARATIONS

### Carrying the Machine

- Carry the machine putting in the storage box.

#### CAUTION

- ◆ The machine is heavy (Vise 8kg, Main Body 11kg), be sure to carry it by two people.  
When lifting it, bend your knees to avoid a load on your waist.
- ◆ Be sure to remove the saw blade when carrying the machine.

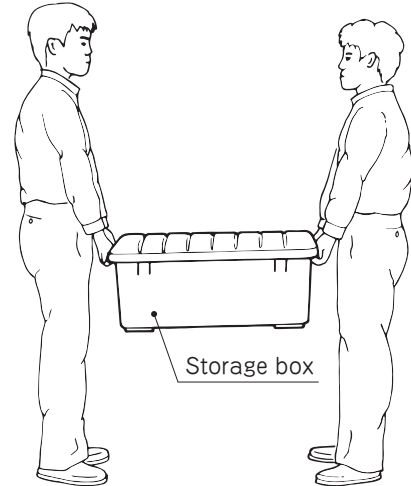

### Maintaining and Checking the Working Environment

- Make sure that the working area is kept proper as described in the "SAFETY INSTRUCTIONS" and "OPERATING INSTRUCTIONS".

#### Noise Prevention Control

- Noise is controlled as set forth in relevant regulations. The machine must be operated at less than the regulated noise to avoid discomfort to the neighborhood.  
Sound barriers may be required under some circumstances.

# PIPE SAW 400SA

## OPERATION

- Before starting operation, always read the instructions in "SAFETY INSTRUCTIONS" and "OPERATING INSTRUCTIONS" (pages 2 to 6).

### ⚠ WARNING

- ◆ **Make sure to close Ball Valve of the unit before connecting Air Hose.**  
If Air Hose is connected to the machine with Ball Valve opened, the unit may start suddenly, leading a serious injury or accident.

## Fixing the vise

### ⚠ WARNING

- ◆ **Vise and main body stained with cutting oil is slippery.**  
**Wipe off the oil completely.**  
Do not drop the machine on your feet when lifting it.
- ◆ **When installing the machine, check the supporting force of the pipe(existing pipes).**  
Do not install the machine to the decrepit pipe.
- ◆ **As this machine is heavy, carefully lift when installing it in the high position.**
- ◆ **Do not install the vise on the "cutting off side."**  
**The cut pipe together with the vise will drop.**  
This is very dangerous.
- ◆ **Fix the vise firmly.**  
If the vise fixing force is weak, the main body may drop or the saw blade may be broken while cutting.
- ◆ **Watch the position of your finger while lowering the vise to avoid pinching of fingers.**

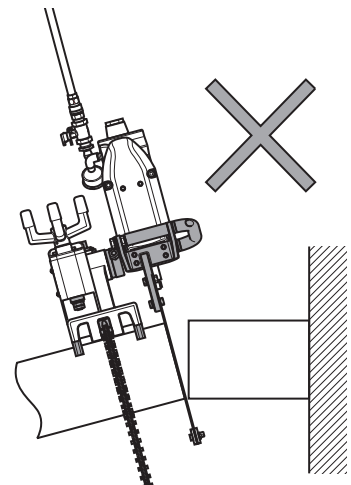

# PIPE SAW 400SA

- ① Mark the cutting position on the pipe.
- ② Completely remove foreign matters and stains from the pipe and vise jaw.  
If the vise is fixed with the foreign matters remained, it may loosen during cutting.  
Or, the pipe cannot be cut straight.
- ③ Mount the vise on the pipe with the vise end face comes to the 50mm away from cutting position.

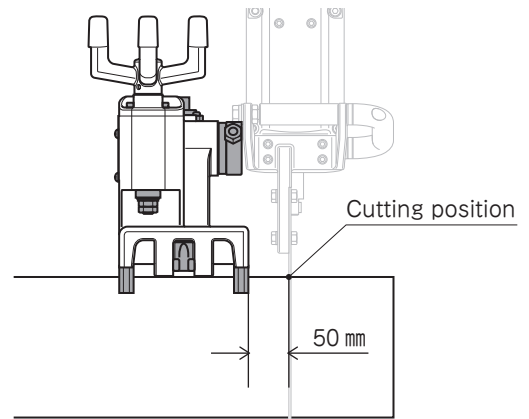

- ④ Using a ratchet wrench, loosen the clamp bolt to the full end.  
As the clamping allowance is not generated if the clamp bolt is not loosened, the vise cannot be fixed. (clamping allowance : 30mm)

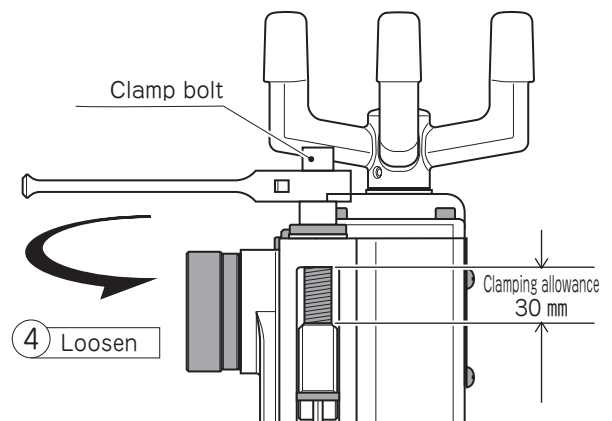

- ⑤ Set a chain on the hook with checking that the chain passes through the inside of chain-receiving roller.  
Also check that the chain is not winding slantingly.

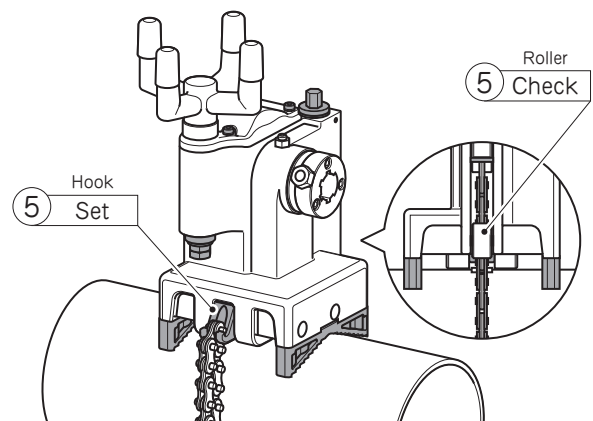

- ⑥ Using the ratchet wrench, rotate the clamp bolt to clamp the chain.(245 ~ 294N)
- ⑦ Keep the remaining chain off the track of saw blade.

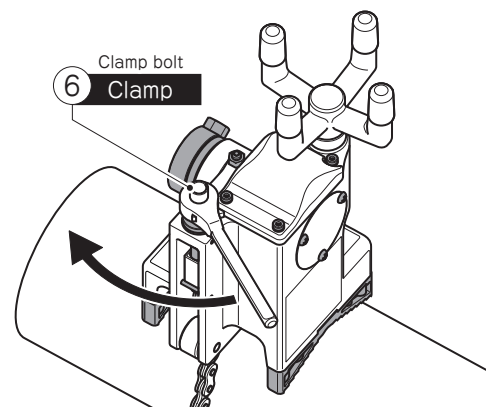

# PIPE SAW 400SA

## How to set the main body

- ① Disconnect the power plug.
- ② Check that there is no foreign matter in the rotary shaft of the main body and the rotary bush of the vise. Remove the foreign matter, if any.
- ③ Firmly holding the main body grip and motor grip with both hands, mount the main body to the vise.

Insert the rotary shaft of the main body into the rotary bush of the vise with adjusting mutual square spline to arbitrary angle and insert the main body up to the full end.

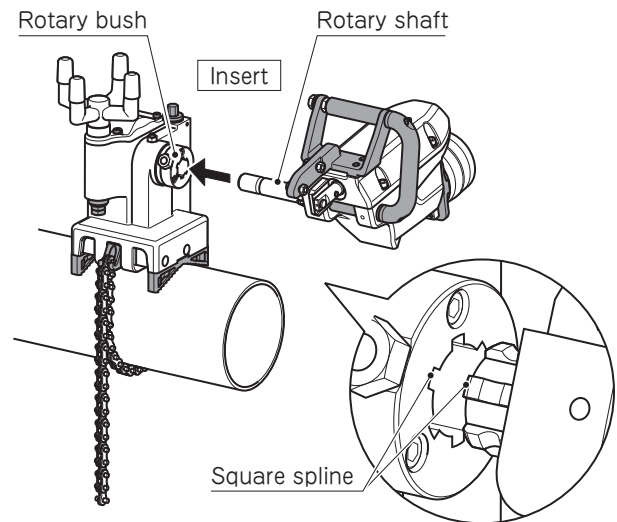

## How to set the Saw Blade

### ⚠ CAUTION

#### ◆ Use the saw blade of the size conforming to the pipe diameter.

If the thick pipe exceeding the cutting capability of the blade, the tip of the saw blade touches the inside of pipe resulting in breaking of the saw blade.

#### ◆ Do not use the damaged saw blade.

As resistance of cutting face increases and load is applied, breakdown is caused.

#### ◆ If clamping of the saw blade is weak, the saw blade may come off during cutting, and the main body and saw blade may be damaged.

- ① Select the saw blade conforming to the size and material of the pipe to be cut.
- ② Insert the saw blade between the "blade holder" and "blade guide," and hook it on the "saw blade fixing bolt" and "mounting pin." (Pay attention to direction of saw blade.)

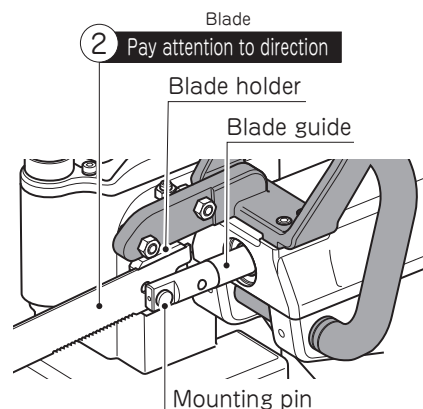

- ③ Clamp the "saw blade fixing bolt" (with flat washer) with the attached ratchet wrench.

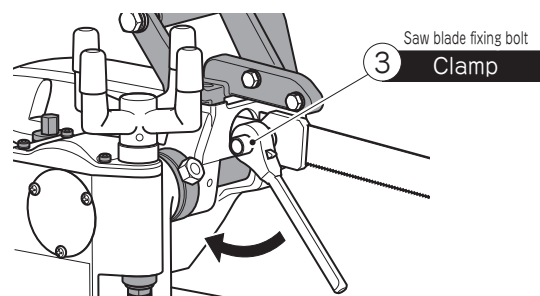

# PIPE SAW 400SA

## How to set the guide plate

- ① Select the guide plate conforming to the size of saw blade.
- ② Set U – notch of "guide plate" to the "guide plate fixing bolt" (2spots) with the back of the saw blade passes through the gap of "guide."
- ③ Fix the "guide plate fixing nut" (2spots) with the attached ratchet wrench.

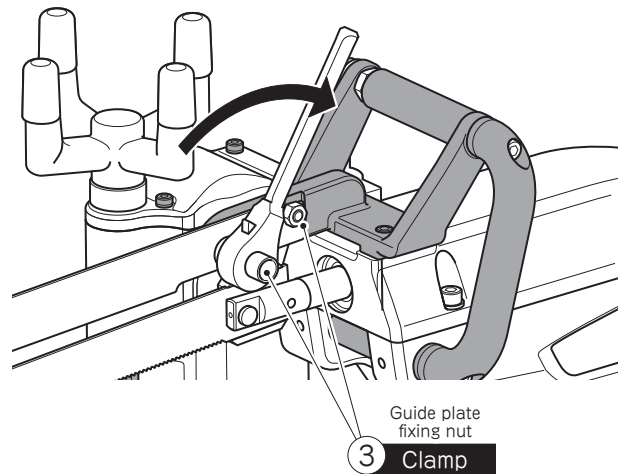
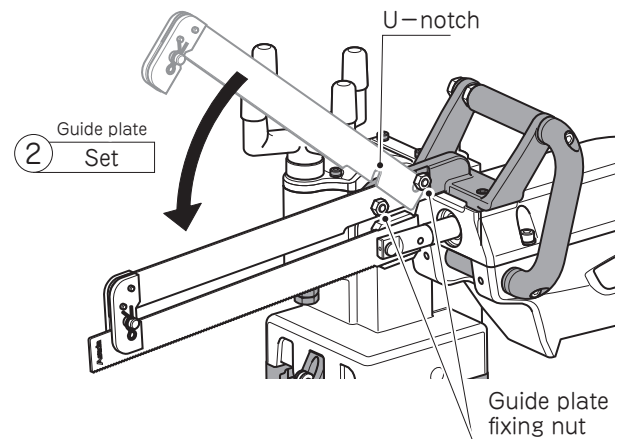

## Installation of Air Maintenance Unit and Air Compressor

- ① Close Ball Valve and connect the machine to Air Maintenance Unit.
- ② Connect Air Maintenance Unit to Air Compressor.

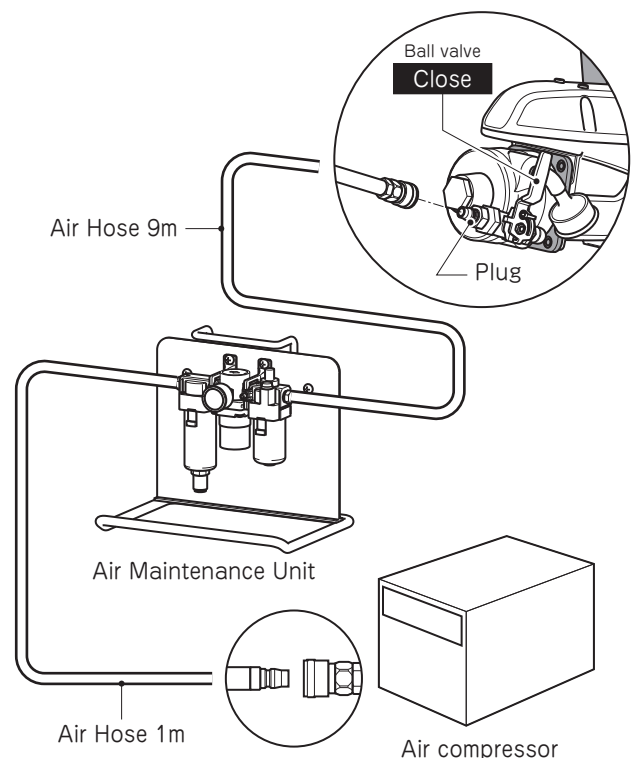

### ⚠ CAUTION

- ◆ Additional extension air hose should not exceed 10m.
- ◆ Inner diameter of the extension air hose should be 9mm or more.  
If the conditions above are not satisfied, the air flow rate will not be secured which causes a lack of the performance.

# PIPE SAW 400SA

## CUTTING

### ⚠ CAUTION

- ◆ When cutting the mortar lining casting pipe, be sure to wear the face mask to prevent dust.
- ◆ Avoid forcible usage which will lead to a saw blade stop during cutting. Adjust the saw blade speed so that the machine cuts the work piece smoothly.

- ① Turn on Air Compressor after making sure that Ball Valve of the unit is closed.
- ② Check that the saw blade is about 10 mm away from the pipe.

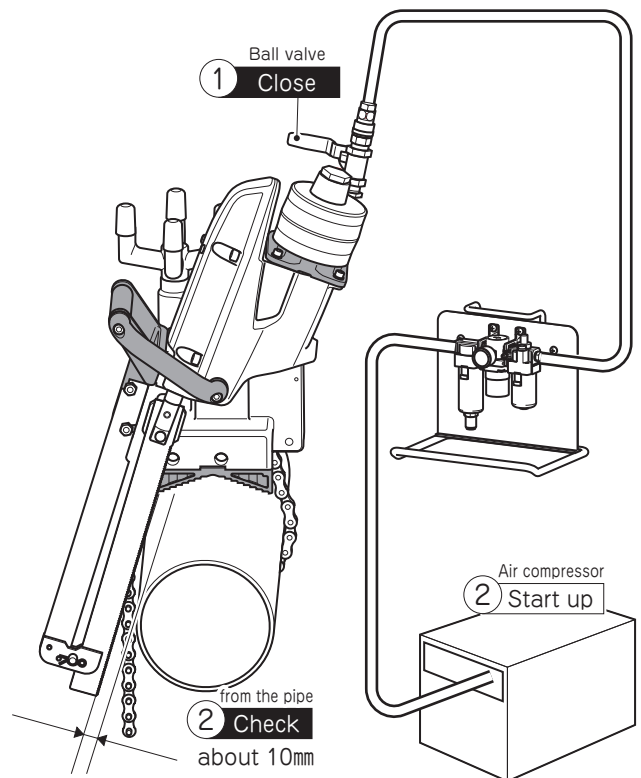

### ③ Air Maintenance Unit

- Lower Regulator Knob for unlocking.
- Set the air pressure to 0.5 ~ 0.7MPa by turning Regulator Knob.  
Set the air pressure to 0.5MPa in case of cutting a stainless steel pipe or resin pipe.  
Turn right : higher the pressure / Turn left : lower the pressure
- Raise Regulator Knob for locking after finishing the adjustment.

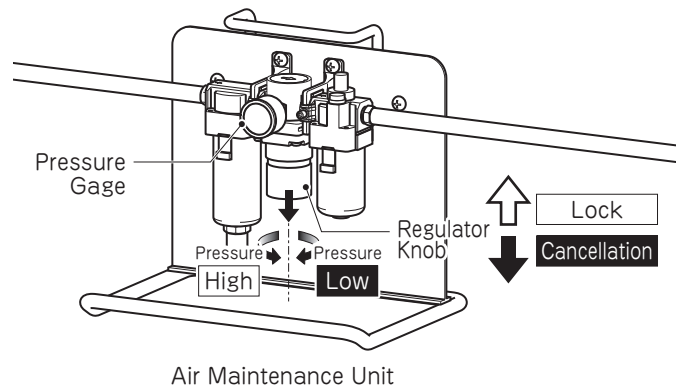

### ④ Adjust that oil drip 5 times per minute by turning the screw of Lubricator.

Turn right : slower the oil dripping / Turn left : faster the oil dripping.

If the oil level of Lubricator reaches the lower limit, fill it with engine oil equivalent to SAE Standard # 10 or 90 Turbine Oil.

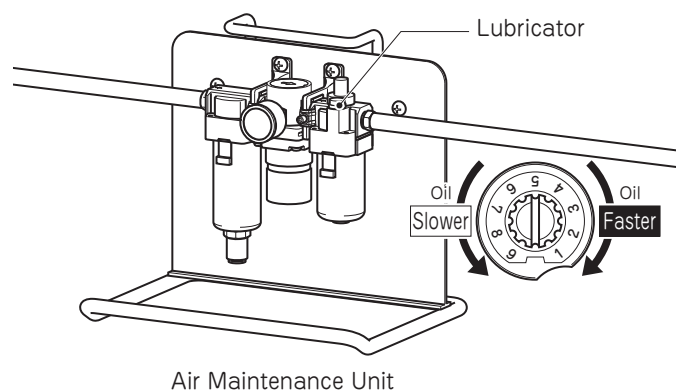



# PIPE SAW 400SA

- ⑤ The air filter of the unit is equipped with auto drain function. Water will be discharged periodically from the bottom of the air filter when it gets collected.

In case of discharging the water manually, turn the knob at the bottom to the left. Return the knob to the original position after draining the water.

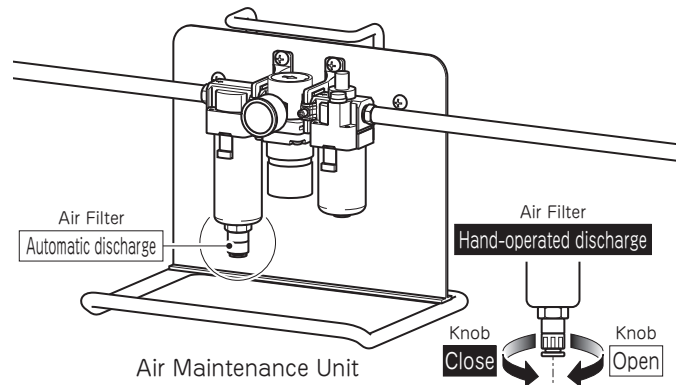

- ⑥ Open Ball Valve gradually to start running the unit.

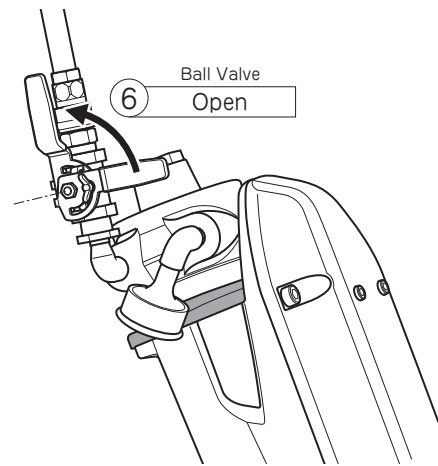

		Pipe thickness	Ball valve	Saw blade	
Pipe	Steel pipe (SGP · STPG)	6mm or less	Fully open	HSS	
		6~9mm			
	Cast Iron (Ductile) pipe (for gas, inside resin coating)	6mm	Fully open		
		7.5mm			
	Cast Iron (Ductile) pipe mortar lining (for water system)	-	Fully open		Grit saw
	Stainless steel pipe	6mm or less	15~30°		HSS For stainless
6~8mm					
Resin pipe	10mm or less	15~30°	HSS		
	10~20mm				

# PIPE SAW 400SA

- ⑦ Rotate the operating handle counterclockwise and cut the pipe slowly.

Rotate the handle with the force that does not decrease the stroke speed.

When the motor gets a heavy load during the operation, the motor automatically stops.

If a motor stops, rotate the operating handle to the clockwise, and, please give cutting speed.

- ⑧ Use the cutting oil depending on the material of pipe.

Material of pipe	Cutting oil (use or not)
Steel pipe	Use
Stainless steel pipe	
Cast Iron (Ductile) pipe	Not use
mortar lining casting pipe	
Resin pipe	

- ⑨ The extent of oblique cut will be reduced by using a blade and Guide Plate for 200A in case of cutting pipes less than 6".

### [ Information ]

- ※ Oil may ooze out depending on the using condition of Air Motor of the machine. This is one of the characteristics of a lubricating air motor and not a defect.

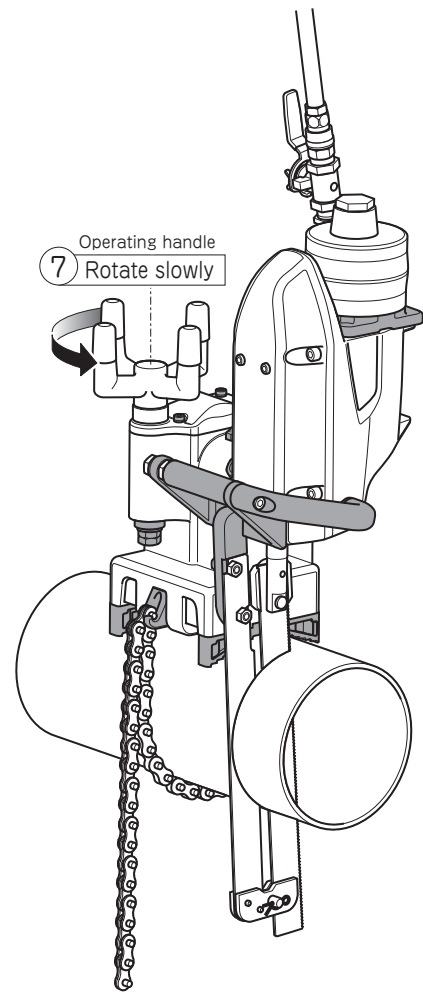

### ⚠ CAUTION

- ◆ **Be sure to use the threading oil white (No.STO14) as the cutting oil.**  
Do not use other cutting oil.
- ◆ **Cutting oil contacting the skin may cause inflammation.**  
Wear protective gloves when handling the cutting oil. In case it contacts your hands, completely wash it off with water and soap.
- ◆ **Wipe off the scattered cutting oil after cutting with oil.**  
The floor may be slippery by cutting oil, causing a fall down.
- ◆ **Do not inhale oil mist or vapor of the cutting oil. It cause nausea.**  
If inhaled accidentally, move to a place where fresh air prevails. Cover the body to keep warm, lie quietly and consult a doctor.
- ◆ **Do not handle or use the cutting oil near a fire.**

- ⑩ After finishing the operation, close Ball Valve, turn Handle clockwise, and stop Air Compressor.

- ⑪ Wait a short time after cutting, remove the components in the order of [Guide plate] → [Saw blade] → [Main body] → [Vise]

# PIPE SAW 400SA

## Cutting the buried pipe

- ① When cutting the buried pipe, dig down to secure working space.

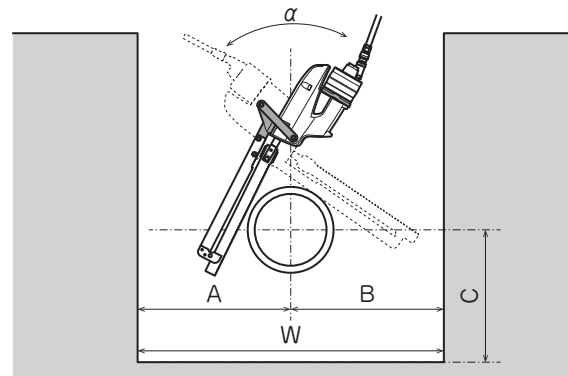

Pipe size	Size A	Size B	Minimum working space W	Size C	Machine working angle
150A	210mm	215mm	425mm	200mm	57°
200A	255mm	265mm	520mm	230mm	64°
250A	300mm	320mm	620mm	260mm	68°
300A	350mm	370mm	720mm	280mm	76°
350A	390mm	420mm	810mm	300mm	83°
400A	450mm	520mm	970mm	380mm	90°

※ Sizes shown here are minimum value. Try to secure the working space as wide as possible.

- ② When cutting the buried pipe, the saw blade may be caught in the pipe by influence of earth pressure. In this case, use a magnet-attached wedge at the cutting port.
- ③ In case of which the blade is stuck between the pipes,
- Close Ball Valve immediately.
  - Drive in Magnet-attached wedge or Chisel and remove the blade.

### ■ How to use the magnet-attached wedge

- ① Drive a magnet-attached wedge at the position where the back of the guide plate is about 30 mm from the cutting start position. (For the thin pipe, remove the guide plate at the position where the back of saw blade is at about 30mm from the cutting start position, and drive the magnet-attached wedge.)
- ② If the wedge cannot be driven by hand, use a plastic hammer etc.

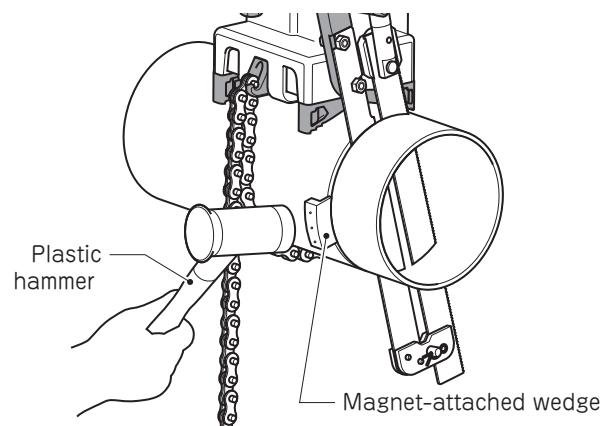

# PIPE SAW 400SA

## Cutting the vertical pipe

### ⚠ WARNING

#### ◆ Vise should be installed by two people.

PIPE SAW 400SA is a heavy item (Vise: 8kg, Unit: 13kg). Installing by one person may cause a serious injury by dropping the unit.

#### ◆ Be sure to set the cut-off side to the top.

The unit may fall together with the cut-off pipe after cutting, causing an injury.

- ① Completely remove foreign matters and stains stuck to the pipe and the vise jaw.
- ② One worker fixes the vise to the vertical pipe with both hands and holds firmly.  
Pay attention to the vise so that the main body comes to the upper side of the vise (cutting section comes to the upper side) .
- ③ Other worker winds the chain of the vise around the vertical pipe, rotates the clamp bolt with the attached ratchet wrench, and fixes the vise. Be careful that the chain easily becomes loose when installed to the vertical pipe. (For winding of the chain and clamping the clamp bolt, refer to page 11 "Fixing the vise.")
- ④ When cutting of the pipe is performed halfway, the saw blade is caught by dead weight of the pipe, Drive the magnet-attached wedge.
- ⑤ The saw blade is caught by dead weight of the pipe when closed to end of cutting. Execute following countermeasures.  
Countermeasure 1 : Drive two or three magnet-attached wedges.  
Countermeasure 2 : Lift up the pipe in advance.
- ⑥ Remove the saw blade, the guide plate, and the main body.
- ⑦ One worker should hold the vise firmly with both hands.
- ⑧ Other worker rotates the clamp bolt with the attached ratchet wrench, loosens the chain slowly, and removes the vise carefully so that it may not drop.

Position of the vise

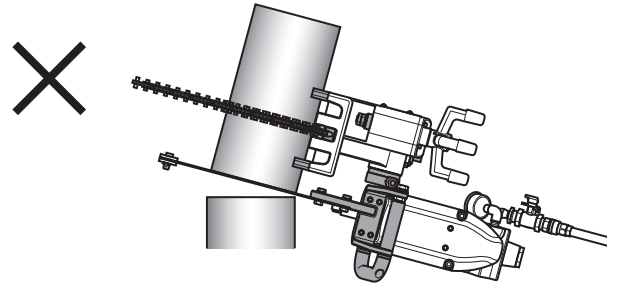
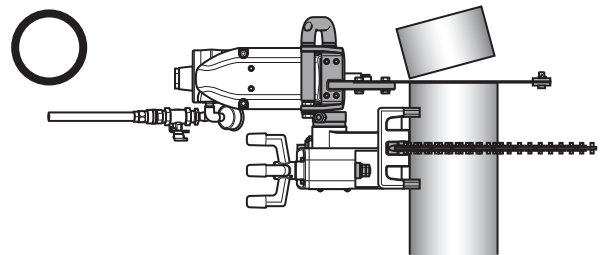

Countermeasure

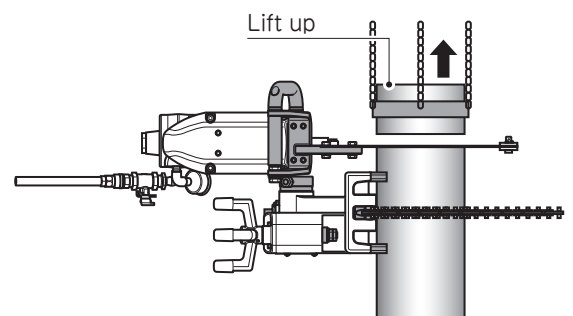
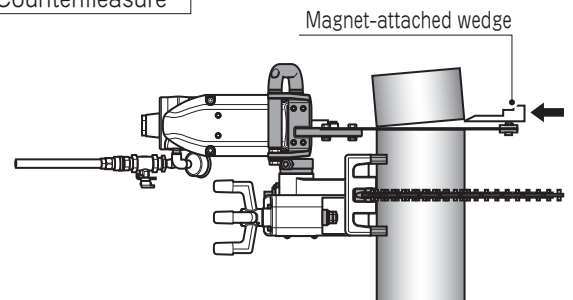

# PIPE SAW 400SA

## Cleaning the Parts

- Clean chips, mud, sand, and water stuck to the saw using the wire brush.  
Wipe off cutting oil scattered on the machine or in the area using waste cloth.

 CAUTION

- ◆ **Do not blow off chips using compressed air.**  
They may get into eyes and loss of eyesight may result.
- ◆ **As the chips are sharp, do not touch with bare hands. Be sure to wear gloves.**

# PIPE SAW 400SA

## MAINTENANCE & INSPECTION

### ⚠ WARNING

◆ **Before starting inspection or maintenance, always turn the switch off and disconnect the attachment plug from the receptacle.**

The machine will start running suddenly, it will lead to accident or injury.

● Check, clean and repair / replace the following areas regularly.

Maintenance & Inspection	Action
Check the air hose for damage.	Replace if any damage is found.
Check the saw blade for chipping or damage.	Replace if chipping is found. (For the saw blade replacing procedure, refer to page 13 "How to Set the Saw Blade".)
Inspection and replacement of Guide pin.	Remove and replace the worn Guide pin as illustrated right. (No.58510 Guide pin)
Check if screws are loosen and tight them up if .	Retighten any loosed screws.
Oiling the Parts.	Oil the following parts periodically (Use machine oil sold in the shop.) <ul style="list-style-type: none"> <li>• Saw guide</li> <li>• Rotary shaft and rotary bush</li> <li>• Operating handle slide way</li> </ul>
Check the Saw Guide carefully that there is no chips, mud, sand, water and so on.	If chips, mud, sand, water, etc. remain sticking to the Saw Guide, the Saw Guide will rust and lead to a failure. Always clean the Saw Guide before storing the machine.
Remove stain from the machine and keep clean.	The outer frame of the machine is made of rigid synthetic resin. However its surface will be damaged by gasoline, thinner, petroleum and kerosene. When cleaning, wipe its surface with a dry cloth or a cloth immersed in soap suds.
Keep them in safe and dry places.	Do not store the machine at following places: <ul style="list-style-type: none"> <li>• Where children can reach and take the machine easily.</li> <li>• Where exposed to rain or humidity.</li> <li>• Where sudden temperature changes.</li> <li>• Under direct sunlight.</li> <li>• Near volatile material which may ignite or explode.</li> </ul>

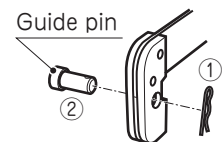

# PIPE SAW 400SA

## TROUBLESHOOTING

- Before asking for repairs, check following troubleshooting.  
If the problem cannot be solved, contact with the shop you purchased or our sales office.
- Troubles due to misuse or improper applications are not covered by warranty.

Phenomenon	Cause	Measures
Insufficient power	Lack of capacity of air compressor	Use Air Compressor more than 15HP.
	Low air pressure	Set the air pressure to 0.5~0.7MPa by turning Regulator Knob.
	Air leakage from air motor	Contact our distributor for repairing.
	Air leak from air hose	Replace Air Hose.
The Saw Blade is broken, and / or is loose	Loosed Clamp Bolt of Blade Holder	Re-tighten Clamp Bolt.
	Forcing the machine to cut	Do not cut by force. Cut slower.
	Unfixed Chain Vise	Fix the Chain Vise to the work piece firmly.
The machine stops during cutting	Lack of capacity of air compressor	Use Air Compressor more than 15HP.
	Low air pressure	Set the air pressure to 0.5~0.7MPa by turning Regulator Knob.
	Worn out saw blade	If the saw blade is worn out, cannot cut properly. Change the saw blade to new one.
Oblique cutting	Worn out saw blade	If the saw blade is worn out, it causes of oblique cutting. Change the saw blade to new one when it's worn out.
	Jammed contaminations between Chain Vise and the work piece	Remove the contamination jammed between Chain Vise and the work piece.
	Forcing the machine to cut	Do not cut by force. Cut slower.

## ● Customer Memo

Please fill in for your record in the future.  
The information is helpful for inquiry and ordering parts.

Products Number :

Date Purchased :

Store Purchased the Unit :