

For precision cutting
at right angle !!

BAND SAW BEAVER SERIES

For cutting steel pipe, conduit pipe, poly vinyl pipe, cast iron pipe, stainless steel pipe, steel material, square pipe, round bar, aluminum frame, etc.



Precise Cutting Feed Adjustment

■ The adjustment device achieves precise cutting for various materials.

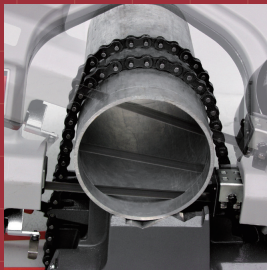

Square Cut (Chain, Flat Vise)

■ Ideal for precision cutting at right angle.

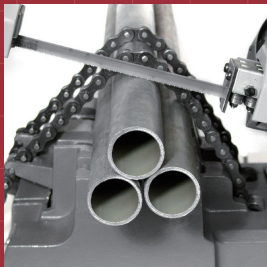

Bundle Cut (Chain Vise)

■ Can cut a bundle of same materials.

Band Saw Beaver 4 Eco
Band Saw Beaver 6
Band Saw 8



Angle Cut (Flat Vise)

■ Cuts material at right angle or mitre cuts from 0° up to 45°.

Band Saw Beaver 4F Eco
Band Saw Beaver 6F
Band Saw 8F
Band Saw 32F

Safety and Harmlessness

■ Cutting safely and harmlessly without sparks, cutting dust and noise.

Over - Load Protection

■ Protect a motor from burnout by over-load protection.

For cutting steel pipes, H steel, square pipes, and round bars

Band Saw Beaver 4 Eco

Code No. **BB400-1**

Steel Pipe : ~ ϕ 130mm (4")

Chain Vise

Over - Load Protector

High speed cut for better productivity.

Can cut a bundle of same materials.

Easy to replace the saw blades from the front side.

Movie



Higher - grade cutting capacity up to ϕ 130mm !!

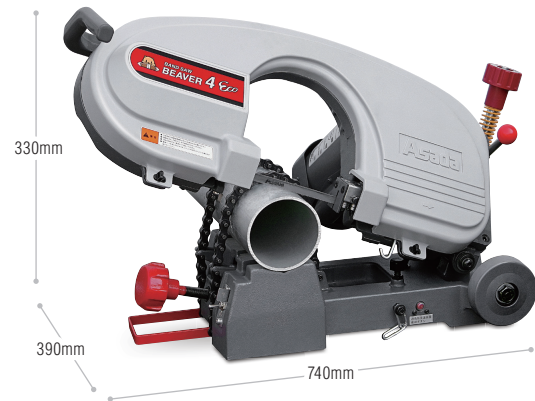

Steel pipe	ϕ 130mm (4")
Cutting Capacity	H - Beam 100mm × 100mm
	Square pipe □100mm
	Round bar ϕ 60mm
Weight	31kg
Motor	220-240V · 200W ※ Voltage made to order
Standard Accessories	14 TPI HSS (1pce): Code No.88915

For cutting steel pipes, H steel, square pipes, and round bars

Band Saw Beaver 4F Eco

Code No. **BB40F-1**

Steel Pipe : ~ ϕ 120mm (4")

Flat Vise

Angle Cut (until 45°)

Over - Load Protector

High speed cut for better productivity.

Can cut a bundle of same materials.

Movie



Quick clamp system helps to set up material quickly !!



Steel pipe	90° : ϕ 120mm (4")	45° : ϕ 50mm (2")
Cutting Capacity	H - Beam 90° : 100mm × 100mm	
	Square pipe 90° : □100mm	45° : □50mm
	Round bar 90° : ϕ 60mm	45° : ϕ 50mm
Weight	33kg	
Motor	220-240V · 200W ※ Voltage made to order	
Standard Accessories	14 TPI HSS (1pce): Code No.88915	

For cutting steel pipes, H steel, square pipes, and round bars

Band Saw Beaver 6

Code No. **BB003-2**

Steel Pipe : ~ ϕ 180mm (6")

Chain Vise

Over-Load Protector

Precise right angle cutting at high speed.
Easy to replace the saw blade from the front side.
Can cut a bundle of same material.



Higher durability with strain prevention rib !!



Steel pipe	ϕ 180mm (6")
Cutting Capacity	H-Beam 150mm \times 150mm
	Square pipe \square 150mm
	Round bar ϕ 80mm
	Weight 42kg
Motor	220-240V \cdot 200W ※ Voltage made to order
Standard Accessories	14 TPI HSS (1pce) : Code No. 70114

For cutting steel pipes, H steel, square pipes, and round bars

Band Saw 8

Standard : Code No. **BB800-3**

Hydraulic : Code No. **BB800H-3**

Steel Pipe : ~ ϕ 220mm (8")

Chain Vise

In addition to the spring damper [Standard] type of precise cutting adjustment model, oil damper [Hydraulic] type is available. Hydraulic type enables to adjust the cutting speed steplessly. Equipped with Over load protection to prevent burning its motor. (Standard & Hydraulic)

Ideal for cutting at right angle !!

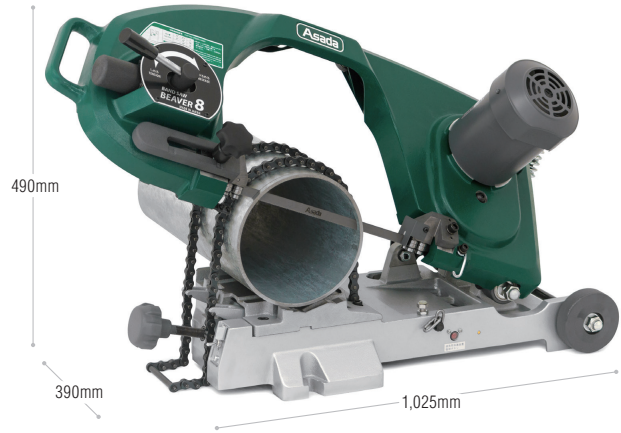

Steel pipe	ϕ 220mm (8")
Cutting Capacity	H-Beam 200mm \times 150mm
	Square pipe \square 175mm
	Round bar ϕ 100mm
	Weight Standard : 52kg Hydraulic : 54kg
Motor	220-240V \cdot 200W ※ Voltage made to order
Standard Accessories	14 TPI HSS (1pce) : Code No. 70446

For cutting steel, H steel, square, and round pipes

Band Saw Beaver 6F

Code No. **BB103-2**

Steel Pipe : ~ ϕ 180mm (6")

Flat Vise

Angle Cut (until 45°)

Over-Load Protector

Precise right angle cutting at high speed.
Easy to replace the saw blade from the front side.
Quick clamp system helps to set pipes quickly.



Quick clamp system helps to set up material quickly !!



Steel pipe	90° : ϕ 180mm (6")	45° : ϕ 77mm (2 1/2")
Cutting Capacity	H-Beam 90° : 150mm \times 125mm	
	Square pipe 90° : \square 150mm	45° : \square 75mm
	Round bar 90° : ϕ 80mm	45° : ϕ 75mm
	Weight 47kg	
Motor	220-240V \cdot 200W ※ Voltage made to order	
Standard Accessories	14 TPI HSS (1pce) : Code No. 70114	

For cutting steel pipes, H steel, square pipes, and round bars

Band Saw 8F

Standard : Code No. **BB80F-3**

Hydraulic : Code No. **BB80FH-3**

Steel Pipe : ~ ϕ 220mm (8")

Flat Vise

Angle Cut (until 45°)

In addition to the spring damper [Standard] type of precise cutting adjustment model, oil damper [Hydraulic] type is available. Hydraulic type enables to adjust the cutting speed steplessly. Equipped with Over load protection to prevent burning its motor. (Standard & Hydraulic)

Simple to replace saw blade with New Tension Handle. Frame falling down protection system assures safe work. Quick clamp system helps to set a material quickly.



Steel pipe	90° : ϕ 220mm (8")	45° : ϕ 115mm (4")
Cutting Capacity	H-Beam 90° : 200mm \times 150mm	45° : 125mm \times 125mm
	Square pipe 90° : \square 175mm	45° : \square 125mm
	Round bar 90° : ϕ 100mm	45° : ϕ 100mm
	Weight Standard : 61kg Hydraulic : 63kg	
Motor	220-240V \cdot 200W ※ Voltage made to order	
Standard Accessories	14 TPI HSS (1pce) : Code No. 70446	

For cutting steel pipes, H steel, square pipes, and round bars

Band Saw 10

NEW

Code No. **BB274-3**

Steel Pipe : ~ ϕ 270mm (10")

Chain Vise



Oil damper system (Hydraulic)

Straight Cut

High Speed Cut

Safe & "No Pollution" "No Spark" "Low Noise" "Dry Cutting"



Cutting Capacity	Steel pipe	90° : ϕ 270mm (10")
	H - Beam	90° : 200mm × 200mm
	Square pipe	90° : □200mm
	Round bar	90° : ϕ 100mm
Weight	56kg	
Motor	220-240V · 200W ※ Voltage made to order	
Standard Accessories	14 TPI HSS (1pce) : Code No. 70446	

For cutting steel pipes, H steel, square pipes, and round bars

Band Saw 32F

Code No. **BS324-3**

Steel Pipe : ~ ϕ 320mm (12")

Flat Vise

Angle Cut (until 45°)

Oil dumper system makes it possible to cut at right angle of large diameter pipe.

Dry cutting without coolant!

Portable machine can cut maximum 12" pipe!!



Cutting Capacity	Steel pipe	90° : ϕ 320mm (12")	45° : ϕ 195mm (7")
	H - Beam	90° : 300mm × 300mm	45° : 200mm × 200mm
	Square pipe	90° : □300mm	45° : □200mm
	Round bar	90° : ϕ 150mm	
Weight	114kg		
Motor	220-240V · 300W ※ Voltage made to order		
Standard Accessories	10 TPI HSS (1pce) : Code No. BS905		

Band Saw Blade

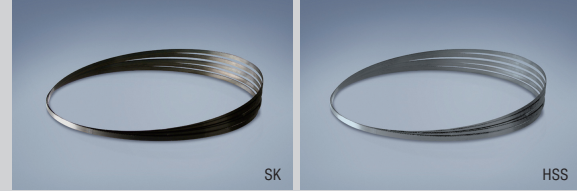

For Band Saw Beaver 4 Eco · 4FEco

Item	Code No.	Quantity
SK 8 TPI	70078	10
SK 10 TPI	88916	10
SK 14 TPI	88887	10
SK 18 TPI	70077	10
SK 24 TPI	88888	10
SK 32 TPI	71069	10
HSS 8 TPI	70132	5
HSS 10 TPI	70075	5
HSS 14 TPI	88915	5
HSS 18 TPI	70603	5
HSS 24 TPI	70413	5
GRIT SAW	70141	5

For Band Saw Beaver 6 · 6F

Item	Code No.	Quantity
SK 8 TPI	70120	10
SK 10 TPI	70121	10
SK 14 TPI	70110	10
SK 18 TPI	70111	10
SK 24 TPI	70112	10
HSS 8 TPI	70133	5
HSS 10 TPI	70113	5
HSS 14 TPI	70114	5
HSS 18 TPI	70602	5
HSS 24 TPI	70257	5
GRIT SAW	70142	5

For Band Saw Beaver 8 · 8F · 10

Item	Code No.	Quantity
SK 8 TPI	70439	10
SK 10 TPI	70440	10
SK 14 TPI	70441	10
SK 18 TPI	70442	10
SK 24 TPI	70443	10
HSS 8 TPI	70444	5
HSS 10 TPI	70445	5
HSS 14 TPI	70446	5
HSS 18 TPI	70493	5
HSS 24 TPI	70447	5

For Band Saw 32F

Item	Code No.	Quantity
HSS 4/6 TPI	BS912	3
HSS 6/10 TPI	BS911	3
HSS 10 TPI	BS905	3
HSS 14 TPI	BS946	3

For cutting existing stainless steel pipes

Pipe Saw 200SP

Code No. **PS201SP**

Steel Pipe : 1/2" ~ 8"
Stainless Steel Pipe : 1/2" ~ 8"※



To cut installed pipes up to 8" fast and easily!!

Easy to work in confined spaces such as under the roof.

Reduction of working time with fast cutting.

Very light weight-Only 3.9kg.



Capacity	Steel	1/2 ~ 8"
	Stainless	1/2 ~ 4" (thickness: 4mm or less) / 1/2 ~ 8" (thickness: 3mm or less)
Stroke length		26mm
Speed		700 ~ 2,060 times/min
Weight		3.9kg
Motor		220 ~ 240V 1,500W ※ Voltage made to order
Standard Accessories		Super HSS Blade 200×8TPI / 270×8TPI (each 1 pce), Chain Vise, Wrench, Plastic case

※ For cutting 8", optional blade '320x6/8' is necessary.



For cutting existing pipes and buried pipes for repairing & dismantling!!

Pipe Saw 380SP

HSS : Code No. **PS386SP**

Grit Saw : Code No. **PS381SP**



Steel Pipe : 2" ~ 12" (14" Optional)
Stainless Steel Pipe : 2" ~ 12"

Available up to 14"!!

Rack&pinion system enables to cut with less physical power.

By adjusting blade speed, also applicable to Stainless steel and Plastic pipes.

Double insulated motor and overload protection system assure safe work.

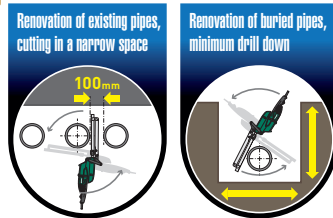

Item	HSS	Grit Saw
Code No.	PS386SP	PS381SP
Application	Steel pipe, Stainless steel pipe, ductile cast iron	Water pipe for ductile cast iron and mortar lining cast iron
Capacity	Steel 2 ~ 12" (14" Optional)	
	Stainless	
Motor	220-240V, 1,300W 50/60Hz	
Stroke length	57mm	
Weight	19kg	
Standard Accessories	Saw Blade HSS 380・490mm (each 1pce), Guide Plate 8"・12", Magnet-Attached Wedge (L), Ratchet Wrench, Case	Saw Blade HSS 380・480mm (each 1pce), Guide Plate 8"・12", Magnet-Attached Wedge (L), Ratchet Wrench, Case



Blade Pipe Saw 165S・200SP



For Pipe Saw 165S・200SP

Item	Code No.	Quantity	Cutting Capacity
140×8 TPI	61210	5	~2"
200×8 TPI	61305	5	~4"
200×6/8 TPI	61327	5	~4"
290×6/8 TPI	61337	5	~6"
320×6/8 TPI	61471	5	~8"

※ Also available for Pipe Saw 150.

Blade for Pipe Saw 165S・200SP (Super HSS)



For Pipe Saw 165S・200SP

Item	Code No.	Quantity	Cutting Capacity
140×14 TPI	61369	5	~2"
140×6 TPI	61370	5	~2"
200×8 TPI	61371	5	~4"
200×6 TPI	61372	5	~4"
270×6 TPI	61458	5	~6"
270×8 TPI	61459	5	~6"
320×6/8 TPI	61486	5	~6"

※ Super HSS includes cobalt. Also available for Pipe Saw 150.

Blade (HSS)



For Pipe Saw 300・350・350M・380S・350A

Item	Code No.	Quantity	Cutting Capacity
320×8 TPI	70310	5	~6"
380×8 TPI	70311	5	~8"
440×8 TPI	70278	5	~10"
490×8 TPI	70279	5	~12"
530×8 TPI	70295	5	~14"
640×8 TPI	70644	5	~16&18"
815×8 TPI	71099	5	~24"

※ Also available for Pipe Saw 150.

Blade Grit Saw

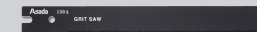

For Pipe Saw 300・350・350M・380S・350A

Item	Code No.	Quantity	Cutting Capacity
320	70288	5	~6"
380	70289	5	~8"
430	70260	5	~10"
480	70261	5	~12"
530	70262	5	~14"

For cutting gas ductile iron, steel, reversal sealing pipes

Pipe Saw 400SA

NEW

Code No. **PS401SA**

Steel Pipe : 2" ~ 12" (24" Optional)
Stainless Steel Pipe : 2" ~ 12"

No spark with Air motor!

Ideal for removing oil, gas, and water pipes.
Air hose can be extended as you like.
Rack&pinion system enables to cut with less physical power.
Double insulated motor and overload protection system assure safe work.

Cold cutting for offshore oil & gas piping!!



Capacity	Steel	2~12" (24" Optional)
	Stainless	2~12"
Motor	Air motor 1,120W	
Stroke length	57mm	
Speed	40~400 times/min	
Weight	21kg (body + vise)	
Standard Accessories	Saw Blade HSS 380・490mm (each 1pce), Guide Plate 8"・12", Magnet-Attached Wedge (L), Ratchet Wrench, Air maintenance unit, CaseX2	

For cutting water ductile iron, lining motor pipes

Pipe Saw 300/ 350 PAT.

300 : Code No. **58003**

350 : Code No. **58013**

300 : 2" ~ 14" (18")
350 : 2" ~ 14"

Flexible Shaft System

Flexible Shaft System. Ideal for cutting gas pipes!

Ideal for dismantling and assembling underground gas pipes.
Flexible shaft system eliminates the problem of sparks and makes it possible to cut pipes with water inside.
Compact and easy cutting with rack & pinion system.
Equipped with a low noise condenser motor allows you to work at night.
※ To cut 18", optional accessories are necessary.

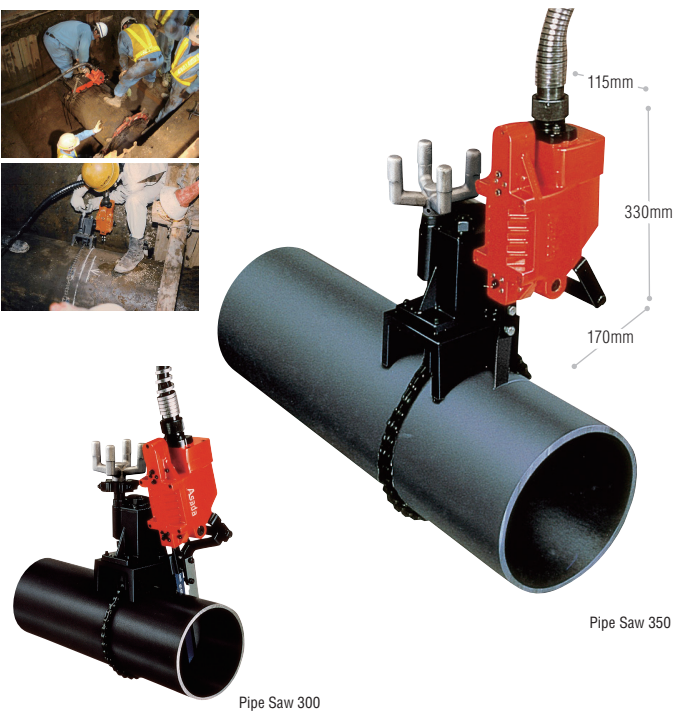

Pipe Saw 350

Pipe Saw 300

Item	Pipe Saw 300	Pipe Saw 350
Code No.	58003	58013
Power transmission	Flexible shaft system	
Stroke length	57mm	
Weight	57kg	
Motor	100V 750W ※ Voltage made to order	
Standard Accessories	HSS 320, 380, 490mm, Guide Plate 200AG・300AG	Grit saw 320, 380, 430, 480, 530mm (1 pce each) Guide plate 250AW, 300AW, 350AW

Blade HSS (for stainless)



For Pipe Saw 380S

Item	Code No.	Quantity	Cutting Capacity
440×8 TPI	70305	5	~ 10"
490×8 TPI	70304	5	~ 12"

Guide Plate for Pipe Saw



For Pipe Saw 300・350・350A (※)

Size	Code No.	Applicable Pipe Saw blade
200AG	58524	Code No.70311
250AG	58703	Code No.70278・70305
300AG	58520	Code No.70279・70304
350AGW	58706	Code No.70295
400AGW	58528	Code No.70644
450AGW	58529	Code No.70644

For Pipe Saw 300・350・350A (※)

Size	Code No.	Applicable Pipe Saw blade
200AW	58711	Code No.70289
250AW	58521	Code No.70260
300AW	58522	Code No.70261
350AW	58523	Code No.70262

For Pipe Saw 380S

Size	Code No.	Applicable Pipe Saw blade
200A	PS301	Code No.70311・70289
250A	PS261	Code No.70278・70305・70260
300A	PS262	Code No.70279・70304・70261
350A	PS263	Code No.70295・70262
400A	PS554	Code No.70644
450A	PS347	Code No.70644
600A	PS555	Code No.71099

※ Use Guide Plate applicable to maximum diameter.